

FONTAINE®
VELOCITY
OPERATOR'S MANUAL

Dollar for dollar... the best steel trailer in the industry



Contents

Read this manual carefully and completely before operating or performing maintenance on your Fontaine Trailer. If you have any questions regarding your Fontaine Trailer, please contact Fontaine Tech Services by email at: techsupport@fontainetrailer.net

Section 1 - Operating Instructions

Operating Instructions 3
 Operating Limits And Restrictions..... 4
 Decal Locations..... 5
 Landing Gear 8
 Suspension System: Axle Alignment..... 9
 Suspension System: Ride Height Adjustment 11
 Suspension System: Height Control Valve Adjustment..... 13
 Anti-Lock Braking System 14
 Anti-Lock Braking System: Lamp Codes 15
 Coupling and Uncoupling 16
 Accessing The Trailer Deck 19
 Load Securement: Anchor Points Working Load Limits 20
 Load Securement: Winch and Strap..... 21
 Load Securement: Chain..... 22
 Load Securement: Container Locks 23
 Load Securement: Lashing Rings 24
 DOT Bulkhead Securement..... 25

Section 2 - Optional Features and Instructions

Sliding Suspension Operation..... 27
 Sliding Suspension Positioning 27
 Tire Carrier Bolt-On Type 28
 Tire Storage Area Between Mainbeams..... 30
 Rear Unloaders 31

Section 3 - Preventive Maintenance

Routine Maintenance..... 32
 Basic Maintenance Schedule..... 33
 Lubrication Notes 34
 Basic Trailer Maintenance 34
 Leaf Type Springs Care And Maintenance 35
 Wheel and Rim Care..... 35
 How To Service And Install Wheel Bearings 36
 Wheel Installation and Maintenance..... 37
 Self Adjusting Slack Adjuster 39
 Tips for Prolonged Brake Drum Life..... 40
 Tire Maintenance 40
 Demounting and Mounting Tires..... 42
 Electrical System..... 43
 Care of Wood Decking for Platform Trailers..... 44

Section 4 - Troubleshooting Guide

Brakes..... 45
 Wheels, Tires and Alignment 46
 Landing Gear 47
 Electrical System..... 47

Section 5 - Important Information

Fontaine Trailer Parts 48
 NHTSA Reporting 49
 APPENDIX: Component Manufacturers..... 50
 APPENDIX: Trailer Decals for Readability 52
 Index..... 60
 Maintenance Record 62



Operating Instructions

This manual has been prepared to assist you in the safe operation and maintenance of your **FONTAINE Velocity** trailer. It contains important information on the proper use of your **FONTAINE** trailer and the major components and optional equipment included.

⚠ WARNING

THIS SYMBOL IS USED THROUGHOUT THIS MANUAL TO CALL ATTENTION TO THE PROCEDURES YOU MUST FOLLOW EXACTLY. CARELESSNESS OR FAILURE TO FOLLOW INSTRUCTIONS MAY LEAD TO DEATH OR SERIOUS INJURY.

⚠ CAUTION

THIS SYMBOL INDICATES A PROCEDURE YOU MUST FOLLOW EXACTLY OR DAMAGE TO COMPONENTS OR EQUIPMENT MAY OCCUR. SERIOUS PERSONAL INJURY MAY ALSO RESULT FROM FAILURE TO FOLLOW THIS PROCEDURE.

NOTE

THIS SYMBOL IS USED THROUGHOUT THIS MANUAL TO CALL ATTENTION TO OPERATIONS, PROCEDURES AND INSTRUCTIONS THAT ARE IMPORTANT FOR PROPER SERVICE. IT MAY ALSO INDICATE INFORMATION THAT CAN MAKE SERVICE QUICKER OR EASIER.

All operator instructions are provided for assistance in the proper operation of your trailer. Specific component operating instructions and your company's procedures should be consulted. These may include DOT and employer training programs or instructions.

This manual includes safety checks the trailer operator must perform.

It is important that every trailer owner and/or operator have an organized Trailer Preventive Maintenance program (TPM). The United States Department of Transportation requires by law that maintenance records be kept on every commercial highway vehicle. It is to your advantage to be able to show that regularly scheduled TPM inspection checks have been made on every piece of equipment operated.

A regular TPM program will not only assure you will get the most usage from your trailer, but will also assist in demonstrating that the equipment has been properly maintained.

You can get help in setting up and operating a trailer preventive maintenance program by sending for a "**Maintenance Manual for Trailers and Containers**". Contact the **Truck Trailer Manufacturers Association**, 1020 Princess Street, Alexandria, Virginia 22314.

IMPORTANT

Read this manual carefully. Should you have any questions, contact a FONTAINE factory representative immediately.

1-800-821-6535

**For Warranty and
Technical Service call
1-205-485-1304**

**For Trailer Parts contact
Fontaine PartSource
parts@fontainetrailer.net**

This manual should be kept with the trailer at all times and should be left with the trailer when/if it is sold.

www.fontainetrailer.com



Operating Limits And Restrictions

This FONTAINE trailer was designed for operation within legal highway speed limits on reasonable road surfaces for the type of service it was built to perform in accordance with the following:

1. This trailer was built to carry cargo within the limitations of two weight ratings on the identification plate. These ratings, GAWR and GVWR, are:
 - a. The GAWR (gross axle weight rating) is the structural capability of the lowest rated member of the running gear components: suspensions, hub, wheels and drums, rims, bearings, brakes, axles or tires.
 - b. The GVWR (gross vehicle weight rating) is the structural capability of the trailer when supported by the kingpin and axles with the load uniformly distributed throughout the cargo space, as defined by the V. I. N. plate.
2. The Concentrated load rating is the structural capability of the trailer frame for non-uniform loads that are concentrated on the deck of the trailer in a specified location. Contact a Fontaine Dealer or Representative for the concentrated rating for your Trailer.

⚠ WARNING

THE PUBLISHED GVWR, GAWR, AND CONCENTRATED LOAD RATINGS SHOULD NEVER BE EXCEEDED.

NOTE

THE MAXIMUM LOAD INDICATED ON THE IDENTIFICATION PLATE MAY OR MAY NOT BE A LEGAL LOAD ON THE HIGHWAY YOU PLAN TO USE.

3. The cargo should be properly loaded, blocked and braced to prevent load shifts and to comply with the following sections of the Department of Transportation Regulations, Subpart 1 – Protection against Shifting and Falling Cargo:
 - **Section 393.100** – General rules for protection against shifting or falling cargo.
 - **Section 393.102** – Securement systems. To properly secure cargo, it is important that the working load limits of the tie downs be known. As well as the working load limit of the anchor points.
 - **Section 393.104** – Blocking and Bracing.
 - **Section 393.106** – Front-end structure. Your trailer may or may not be equipped with a “rated” bulkhead. It is your responsibility to ensure to ensure with 393.106.

Beginning March 1, 1998 all trailers are required by law to have anti-lock brake systems on at least one axle per FMVSS-121 (49CFR 571.121). A “**4S-2M**” system means there are 4 sensors and 2 modulator valves controlling the axles while a “**2S-1M**” system is 2 sensors and 1 modulator valve. Refer to the manufacturer of the ABS system for specific information on the various components.

Decal Locations

NOTE

DECALS ARE AN IMPORTANT PART OF THE TRAILER OPERATION. KNOWING WHERE DECALS ARE LOCATED AND WHAT INFORMATION THEY CONVEY WILL HELP IN THE MAINTENANCE OF THE TRAILER, THE SAFE OPERATION OF THE TRAILER AND IN MAINTAINING COMPLIANCE WITH STATE AND FEDERAL REGULATIONS.

NOTE

IF ANY OF THESE DECALS ARE MISSING CONTACT FONTAINE TRAILER COMPANY FOR REPLACEMENT INFORMATION. THE FOLLOWING DECALS REPRESENT THE STANDARD DECALS AND THEIR LOCATIONS AT THE TIME OF PRINTING / TRAILER MANUFACTURE.

Front Decals (See pages 41-48 for larger and easier to read decals)

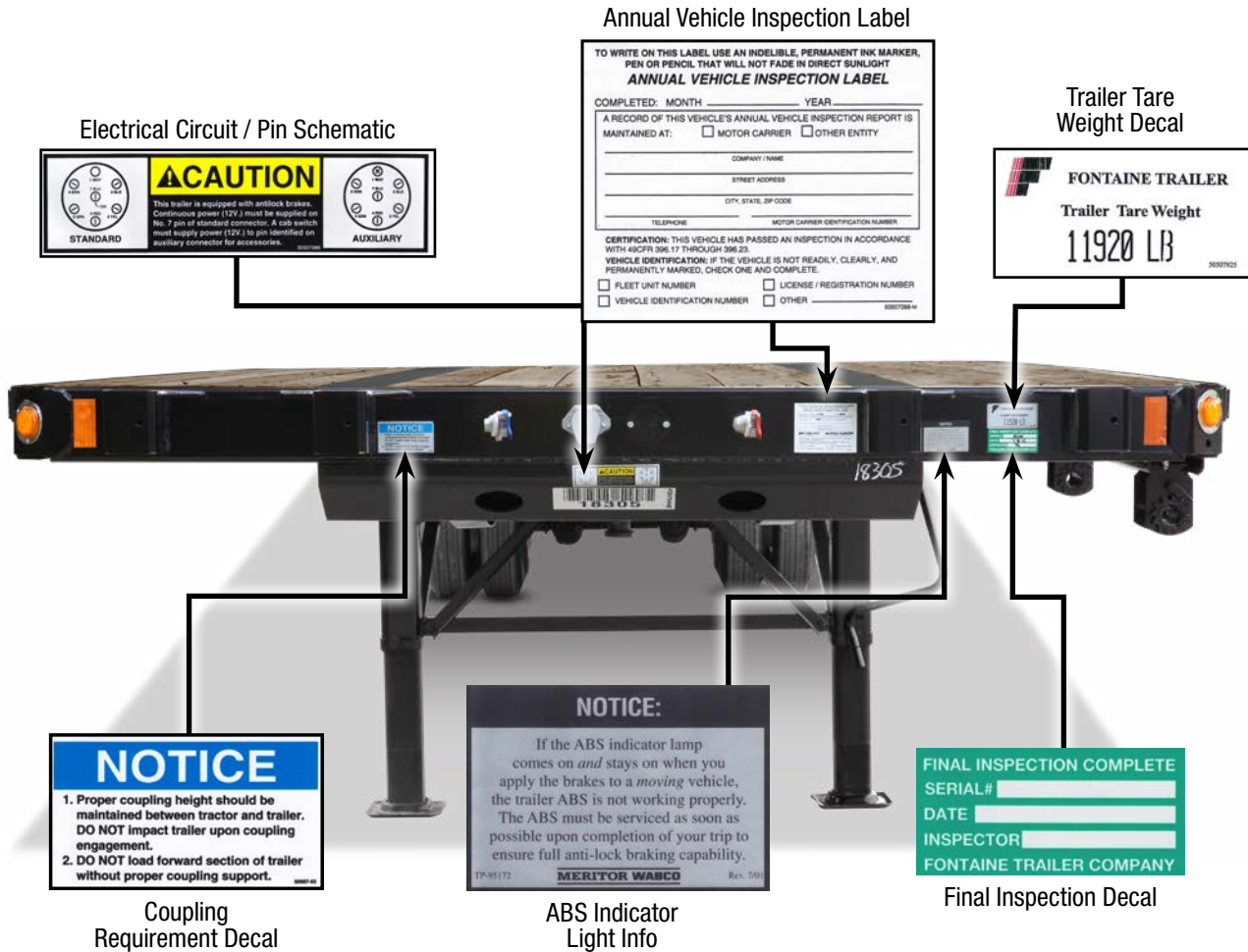

NOTE:

The decals appearing above are only a representation of some of the decals that may be found in this area of your Fontaine Trailer. The decals above are not, and are not intended, to provide a complete representation of the decals that may be placed in this area.



Decal Locations

Side Decals (See pages 41-48 for larger and easier to read stickers)



Strap Direction Decal
Located on both sides in front of the landing gear

VIN Plate Location



Single Coil Decal

The Coil Package itself is generally located mid-way between the trailer king pin and the center of the trailer suspension. The Velocity Trailer Coil Package consist of 4 additional floor sills in addition to our 12" cross member spacing. Concentrated loads should be placed in this area.

NOTICE
This trailer is equipped with automatic slack adjusters. Consult maintenance manual before adjusting.

NOTICE:
If the ABS indicator lamp comes on *and* stays on when you apply the brakes to a *moving* vehicle, the trailer ABS is not working properly. The ABS must be serviced as soon as possible upon completion of your trip to ensure full anti-lock braking capability.
MERITOR WABCO Rev. 7/01

ABS Indicator Light Info



Vendor decals related to the suspension or the operation of the suspension are located in this area. These decals will change based on trailer specifications.

VELOCITY

NOTE:

The decals appearing above are only a representation of some of the decals that may be found in this area of your Fontaine Trailer. The decals above are not, and are not intended, to provide a complete representation of the decals that may be placed in this area.



Landing Gear

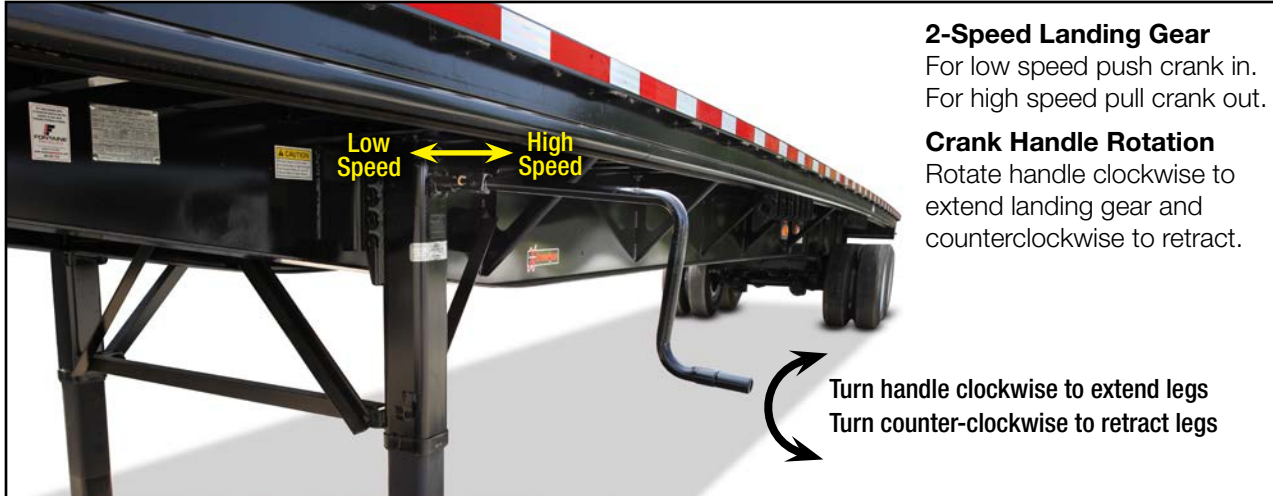

2-Speed Landing Gear
 For low speed push crank in.
 For high speed pull crank out.

Crank Handle Rotation
 Rotate handle clockwise to extend landing gear and counterclockwise to retract.

Your Fontaine trailer is equipped with an OEM selected landing gear designed to meet the needs of the industry. The mechanism features 2-speeds for operator convenience. Push the crank handle in for low speed and pull the crank handle out for high speed. Rotate the crank handle clockwise to extend landing gear, and counterclockwise to retract the landing gear.



CAUTION

1. Do not over extend landing gear.
2. Never drop trailer on landing gear. Always extend landing gear until the landing gear foot contacts the ground, then lift the trailer approximately 1 inch before removing the tractor from the trailer.
3. Always ensure that the landing gear foot rests on a hard surface capable of supporting the trailer and load (hard ground, concrete etc.).
 If necessary, place foot pads on a support plank to prevent the landing gear from sinking into the surface.
4. Always retract landing gear fully before moving the trailer.
5. Always store the crank in the crank holder after extending or retracting the landing gear.
6. Replace all damaged or worn parts.
7. Failure to replace worn or damaged riser nut and retracting screw assembly could cause a failure.

NOTE

LANDING GEAR BOLTS . . .

USE A MINIMUM 5/8" GRADE-5 BOLT ON ALL LANDING GEAR CONNECTIONS EXCEPT ON CROSS PIPE. ON CROSS PIPE USE A MINIMUM 5/16" GRADE-5 BOLT.

NOTE

TORQUE CHART . . .

5/16" Grade - 5	17 Ft Lbs Dry	13 Ft Lbs Oiled
5/8" Grade - 5	150 Ft Lbs Dry	110 Ft Lbs Oiled



Suspension System: Axle Alignment

Your Fontaine Trailer is equipped with either an air ride suspension or mechanical spring suspension. Common suspension suppliers to Fontaine include Hendrickson, Meritor and Hutch. Additional information including installation, service, maintenance recommendations warranty and general sales data for all of the systems can be found on their websites. Links to their website are shown below.

Hendrickson: www.Hendrickson-Intl.com

Meritor: www.meritor.com

Hutchens Industries: www.hutchensindustries.com

AXLE ALIGNMENT

SINGLE AXLE TRAILERS

1. Raise or lower the landing gear legs to position trailer kingpin plate at design height if known (use 49" if actual design height is unknown).
2. Remove the outer wheel assembly or the outer tires and rims, depending on the wheel equipment.
3. Remove any parts from under the chassis that can interrupt measuring the distance between the king pin and the ends of the axle.
4. Attach a steel measuring tape to a hook and the hook over the kingpin. Measure the distance "A" and "B" from the king pin to the ends of the axle. The difference between the "A" and "B" measurements must not exceed 1/8" (3.2mm).

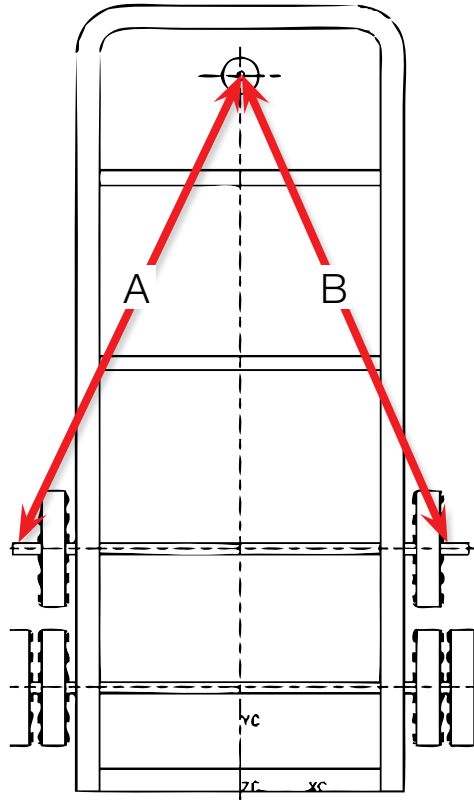

Suspension System: Axle Alignment

TANDEM AXLE TRAILERS

Measuring the alignment of a tandem axle trailer is not very different from the procedure for the single axle trailers. The trailer must be correctly positioned before making the necessary measurements.

1. Move the trailer forward and backward over a level floor, two or three times with the last movement forward, to permit the suspension to become correctly aligned to center the front and rear wheel tracks.
2. Raise or lower the landing gear legs to position trailer kingpin plate at design height if known (use 49" if actual height is unknown).
3. Remove the outer wheel assembly or outer tires and rims.
4. Remove any parts from under the chassis that can interrupt measuring the distances between the kingpin and the ends of the forward axle.
5. Attach a steel measuring tape to a hook and the hook over the kingpin. Measure the distance "A" and "B" from the king pin to the ends of the forward axle. The difference between the "A" and "B" measurements must not exceed 1/8" (3.2mm).
6. Measure the distance "C" and "D" between the front and rear axle centers. The difference between "C" and "D" measurements must not exceed 1/16" (1.6mm). See art below.

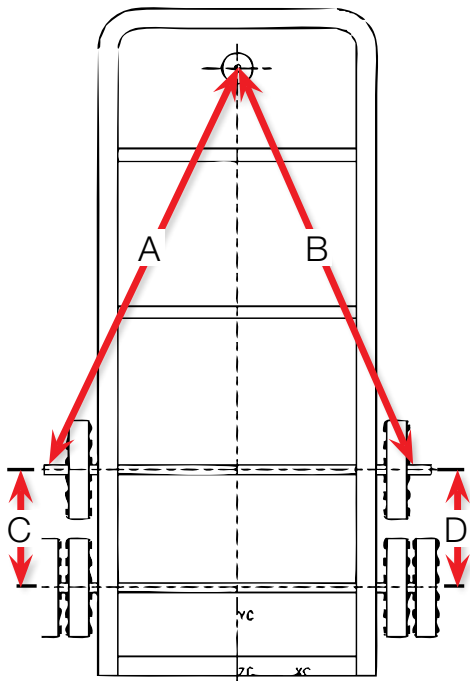

How to Correct the Alignment of Axles

NOTE

THE LIMITS OF 1/16" (1.6MM) AND 1/8" (3.2MM) ARE THE INDUSTRY STANDARD LIMITS FOR CORRECT ALIGNMENT OF THE AXLES. THESE SMALL VARIANCES PERMITTED BY THE STANDARD MAKE ACQUIRING ACCURATE MEASUREMENTS ALL THE MORE IMPORTANT AND CRITICAL TO THE PROPER OPERATION OF YOUR TRAILER.

To correct alignment measurements that are not within the limits, inspect the suspension for worn, broken or loose parts. Adjustment to the suspension, and the replacement of worn or broken parts, must be made to achieve an acceptable axle alignment.

CAUTION

CAREFULLY FOLLOW THE SERVICE INSTRUCTIONS MADE AVAILABLE BY THE SUSPENSION MANUFACTURER WHEN WORKING ON THIS COMPONENT.

NOTE: SEE HENDRICKSON PROCEDURE L579 FOR MORE DETAILED INFORMATION.

www.Hendrickson-Intl.com

Suspension System: Ride Height Adjustment

CHECKING TRAILER RIDE HEIGHT

Operating your trailer with proper ride height is critical to ensure proper load distribution between axles. The next section will identify how to check and adjust your ride height if necessary.

PREPARATION

1. Unload the trailer and park it on flat, level ground that is free of stones and debris.
2. Chock the wheels (Figure 1).



Figure 1: Chock the wheels.

3. Check air pressure in tires. If necessary, inflate tire(s) to proper pressure.
4. Maintain pressure in the air system.

DESIGNED KINGPIN HEIGHT MEASUREMENT

1. Measure the trailer's kingpin height. The trailer may or may not be connected to a tractor during the measurement.
2. If necessary, adjust the landing gear to place the trailer at the designed kingpin height. The standard design kingpin height for a Fontaine Trailer is 49 inches for both flat and step decks. Contact Fontaine Trailer Company if you are unsure of your trailer's designed kingpin height.
3. Verify the measurement of the kingpin height on the other side of the trailer.

NOTE

WHEN THE TRAILER AND TRACTOR ARE CONNECTED, THE TRACTOR'S 5TH WHEEL HEIGHT MUST BE EQUAL TO THE DESIGNED KINGPIN HEIGHT OF THE TRAILER. IF THE 5TH WHEEL HEIGHT DOES NOT EQUAL THE DESIGNED KINGPIN HEIGHT, DISCONNECT THE TRACTOR FROM THE TRAILER.

NOTE

WHEN THE TRAILER IS NOT CONNECTED TO A TRACTOR, MEASURE THE DISTANCE FROM THE GROUND TO THE KINGPIN MOUNTING PLATE. AIR PRESSURE TO THE SUSPENSION MUST STILL BE MAINTAINED.

DESIGNED RIDE HEIGHT MEASUREMENT

1. Locate the suspension ID tag on the front of the HT hanger, the front crossmember of the HS slider bogie or on the inside of the suspension beam for the Intraax (Figure 2)



Figure 2: Suspension ID tag

Suspension System: Ride Height Adjustment

- Check the indicated (underlined> number in the following examples to find the designed ride height.

HT product: HT230-14-001

HS slider: HS190T-14-4801A

Intraax: AANT23K 14"

Flats will typically be set at 14"

Drops will typically be set at 6.5"

(If trailer is equipped with wheel pans in lieu of continuous flooring, typical ride height is set at 9")

- Measure the ride height (Figure 4). The designed ride height is the distance from the center of the axle to the mounting surface of the suspension. **Tip:** Measure from the bottom of the flange to the top of the axle and add half of the axle's diameter to the measurement shown on the tape measure.

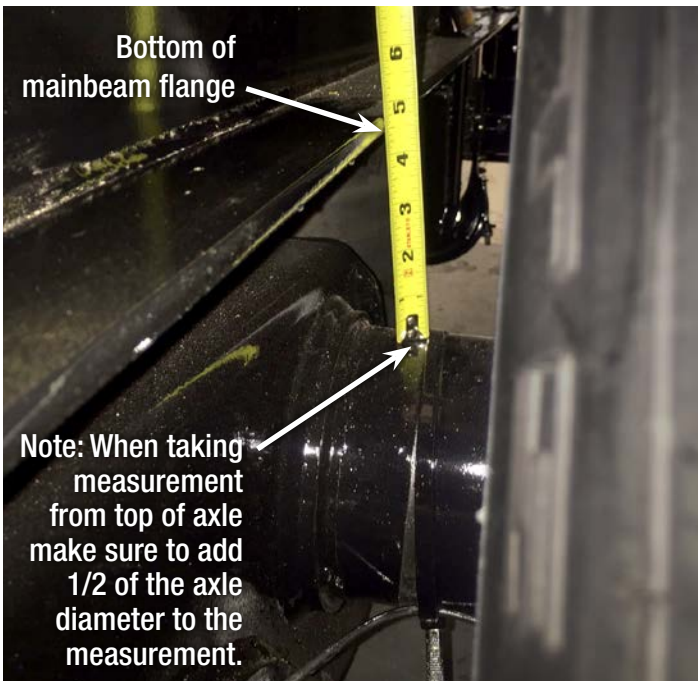

Figure 4: Measure ride height.

NOTE

TO DETERMINE THE RIDE HEIGHT, ADD HALF OF THE AXLE'S DIAMETER TO THE MEASUREMENT SHOWN ON THE TAPE MEASURE. FOR EXAMPLE, A 5" DIAMETER AXLE WOULD HAVE 2-1/2" ADDED TO THE MEASUREMENT AND THE LDA AXLES WITH 5.75" DIAMETER WILL HAVE 2.875" ADDED.

If necessary, adjust the height control valve.

Reference Document L341 at www.Hendrickson-Intl.com



Suspension System: Height Control Valve Adjustment

HEIGHT CONTROL VALVE ADJUSTMENT

(Taken from Hendrickson document L 341)

1. Maintain pressure in the system. See Note below on maintaining proper air pressure for air to flow through the system..
2. Install a locating pin into the adjusting block and bracket on the height control valve.
3. Disconnect the linkage from one end.
4. Remove the pin and push the control arm up to raise or down to lower the ride height until the distance between the vehicle frame and the center of the axle matches the suspension ride height. Re-install the locating pin into the adjusting block and bracket on the height control valve.
5. Adjust the linkage length by separating the two halves and increase or decrease the length to match the attachment points on the height control arm and lower mounting point.
6. Remove the locating pin and verify the ride height prior to putting the trailer back into operation.

NOTE

THERE MUST BE A MINIMUM OF 80 PSI AIR PRESSURE IN THE AIR RESERVOIR TO OPEN THE BRAKE PROTECTION VALVE AND ALLOW AIR TO FLOW THROUGH THE HEIGHT CONTROL VALVE.

NOTE

A 5 TO 10 SECOND DELAY MAY OCCUR BEFORE THE HEIGHT CONTROL VALVE WILL ALLOW AIR TO FLOW TO OR FROM THE AIR SPRINGS.

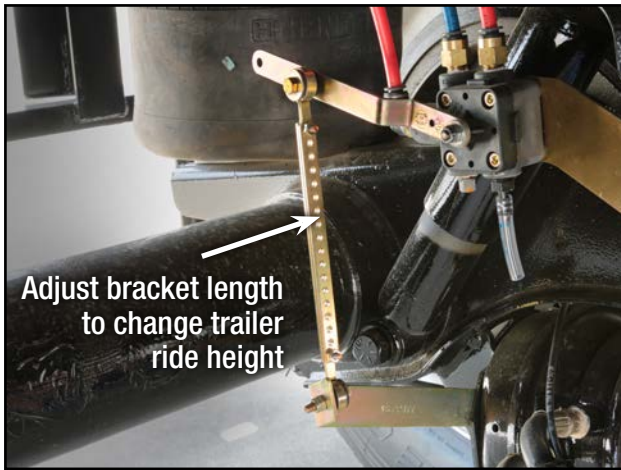

Anti-Lock Braking System

CAUTION

ABS NOTICE - CONNECTOR WIRING CHANGE

NOTICE TO **ALL** TRACTOR TRAILER OWNERS AND USERS

Federal Motor Vehicle Safety Standard No. 121, Air Brakes Systems, was amended by the National Highway Traffic Safety Administration of the DOT to require that truck tractors manufactured on or after March 1, 1997 provide constant power for a trailers antilock brake system (ABS). Some manufacturers will provide this feature before the effect date.

These tractors using a single 7-way electrical connector will have constant power for ABS on the center pin when the key switch is on.

Fontaine, as well as other tractor-trailer owners and users who presently use the center pin for auxiliary power to equipment other than trailer ABS (for example, dome lights, backing lights, bottom dumps, sliding undercarriages, air ride dump valves, etc.) will be affected by this change.

In certain uses of this constantly powered center pin connector, unexpected or unintended activation of this equipment may be hazardous or result in personal injury.

BEFORE connecting your trailer to a tractor, **MAKE SURE** that the constantly powered center pin **WILL NOT UNINTENTIONALLY TURN ON TRAILER EQUIPMENT**. If you have any questions about your present wiring, or how to rewire your vehicles, you should contact Fontaine at **205-485-1300**.

Meritor WABCO Easy-Stop (TM) Anti-lock Braking System (ABS) is standard equipment on all Fontaine trailers with GVWR less than 120,000 lbs. The system monitors wheel speed at all times and improves vehicle stability and control by reducing wheel lock during braking.

CAUTION

ABS INFORMATION IN THIS OPERATOR'S MANUAL WAS PROVIDED BY MERITOR WABCO AND IS SPECIFIC TO ITS PRODUCTS. IF YOUR TRAILER IS EQUIPPED WITH ANOTHER MANUFACTURER'S ANTI-LOCK BRAKING SYSTEM, YOU MUST CONTACT FONTAINE OR THE MANUFACTURER OF THE BRAKING SYSTEM, FOR THE INSTRUCTIONS SPECIFIC TO THAT BRAKING SYSTEM. VISIT WWW.MERITORWABCO.COM FOR MORE INFORMATION.

ELECTRONIC CONTROL UNIT (ECU) MALFUNCTION

In the event of an ECU malfunction, the ABS, in the affected wheels, is disabled. The affected wheels should continue to operate in a non ABS braking mode, if the braking valve itself has not failed. The ABS should continue to operate on the wheels unaffected by the ECU malfunction.

Two ABS indicator lamps (one on the dash of the tractor and one on the side of the trailer) let the driver know the status of the system.

Anti-Lock Braking System: Lamp Codes

ABS INDICATOR LAMP

The ABS Indicator Lamp (amber) is located on the road side (driver side), near the rear marker lamp (red). The lamp is identified with the letters ABS. This lamp indicates the status of the trailer ABS.

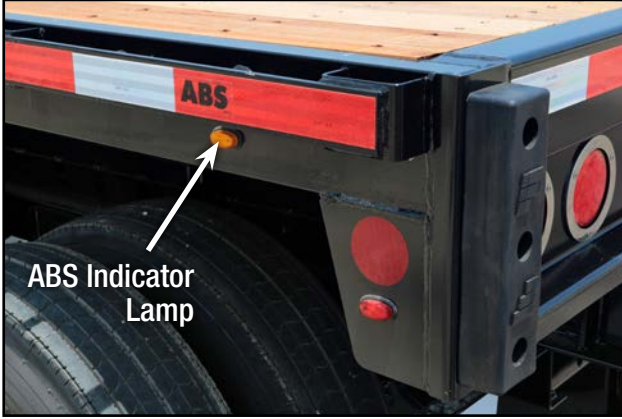

If the ABS lamp comes ON and stays ON when you apply the brakes to a moving vehicle, there is an ABS malfunction. It is normal for the lamp to come ON and go OFF to perform a bulb check, but it should not stay ON when the vehicle is moving about 4 MPH. As with any safety system, it is important not to ignore this indicator. If the indicator lamp indicates a malfunction, the vehicle can be operated to complete the trip. However, it is important to have the vehicle serviced as soon as possible using the appropriate maintenance manual to ensure proper braking performance and to ensure that the benefits of ABS remain available to the driver.

System Is Ignition Powered (constant power)				
Brakes	Ignition	Fault in System	Vehicle Speed	Indicator Lamps (Trailer and Dash)
Released	OFF	N.A.	N.A.	OFF
	ON	NO	Less than 4 mph	ON for 3 seconds then go OFF.
		YES	N.A.	ON
Applied	OFF	NO	Less than 4 mph	ON for 3 seconds then go OFF.
		YES	N.A.	ON
	ON	NO	Less than 4 mph	ON for 3 seconds then go OFF.
		NO	Greater than 4 mph	OFF
		YES	N.A.	ON

Blink Codes: Blink codes are the number of times the ABS lamp blinks on and off. The number of blinks refers to the problem area. See Meritor Wabco Maintenance And Troubleshooting Manual for complete details.

Coupling and Uncoupling

Knowing how to couple and uncouple correctly is basic to safe operation of combination vehicles. General coupling and uncoupling steps are listed below. Different tractors and coupling devices require different techniques, so learn the details for coupling and uncoupling the tractors and coupling devices you operate.

⚠ WARNING

INCORRECT COUPLING AND UNCOUPLING OF YOUR TRAILER CAN RESULT IN ACCIDENTS CAUSING SERIOUS INJURY OR DEATH. NOT ALL TRACTORS ARE IDENTICAL. BE AWARE OF THE DIFFERENCES IN THE VEHICLES YOU OPERATE.

COUPLING

1. INSPECT THE TRACTOR FIFTH WHEEL

- Check for damaged or missing part. Reference the manufacturer's service manual for the fifth wheel in use.
- Check to see that mounting to tractor is secure - - no cracks in frame, etc.
- Be sure the fifth wheel plate is properly greased, failure to do so may cause severe friction leading to loss of control.
- Check if fifth wheel is in proper position for coupling (Wheel tilted down towards rear of tractor, jaws open and safety unlocking handle in the automatic lock position).
- If you have a sliding fifth wheel, make sure it is locked.
- Make sure the trailer kingpin is not bent, broken or damaged in any way.

2. INSPECT AREA AND CHOCK WHEELS

- Make sure area around vehicle is clear.
- Be sure trailer spring brakes are on.
- Check that all trailer cargo is secured against movement.

3. POSITION TRACTOR

- Put the tractor directly in front of the trailer.
- Check position, using outside mirrors, look down both sides of the trailer.

⚠ CAUTION

NEVER BACK A TRACTOR UNDER A TRAILER AT AN ANGLE. PUSHING THE TRAILER SIDEWAYS CAN DAMAGE THE LANDING GEAR OR OTHER STRUCTURES OF THE TRAILER.

4. BACK SLOWLY

- Back until fifth wheel touches the trailer.
- Do not impact the trailer.

5. SECURE TRACTOR

- Apply the parking brake.
- Shift the transmission into neutral.

6. CHECK TRAILER HEIGHT

- The trailer should be low enough so that it is raised slightly by the tractor when the tractor is backed under it. Raise or lower the trailer as needed. Make sure the trailer is proper height and the kingpin and fifth wheel aligned.

⚠ CAUTION

IF TRAILER IS TOO HIGH, IT MAY NOT COUPLE CORRECTLY TO THE TRACTOR. IF IT IS TOO LOW, THE KINGPIN MAY BE STRUCK AND BENT OR THE FRONT OF THE TRAILER MAY BE DAMAGED.

⚠ WARNING

DO NOT WALK OR STAND BETWEEN TRACTOR AND TRAILER. TRACTOR MOVEMENT CAN CAUSE SERIOUS INJURY OR DEATH.

7. CONNECT AIR LINES TO TRAILER

- Check glad hand seals and connect tractor supply (emergency) airline to trailer supply (emergency) gland hand.
- Check gland hand seals and tractor control (service) airline to trailer control (service) gland hand.
- Make sure airlines are supported where they cannot be hung-up or damaged while tractor is backing under trailer.



Coupling and Uncoupling

8. SUPPLY AIR TO TRAILER

- From the tractor cab, push in “air supply” knob or move tractor protection valve control from the “emergency” to the “normal” position to supply air to the trailer brake system.
- Wait until the air pressure is normal.
- Check brake system for crossed airlines.
- Shut engine off to hear brakes.
- Apply and release trailer brakes, listen for the sound of trailer brakes being applied and released.
- Check the air brake system pressure gauge for signs of major loss.
- When sure trailer brakes are working properly, start the engine.
- Check to see that tractor air pressure is greater than 120 psi .

9. LOCK TRAILER BRAKES

- Pull out the “air supply” knob or move the tractor protection valve from “normal (Trailer Brakes Released)” to “emergency (Trailer Brakes Applied)”.

10. BACK TRACTOR UNDER THE TRAILER

- Shift into lowest reverse gear.
- Back tractor slowly under trailer to avoid severely impacting the kingpin.
- Stop when the kingpin is locked into the fifth wheel.

11. CHECK THAT CONNECTION IS SECURE

- Raise trailer landing gear slightly off the ground.
- Gently pull the tractor forward while the trailer brakes are still locked.
- Fifth wheel should be locked into kingpin at this time.

12. SECURE VEHICLE

- Shift the transmission into neutral.
- Apply parking brakes.
- Shut off engine and be sure someone else will not move the truck while you are under it.

13. INSPECT COUPLING

- Use a flashlight if necessary.
- Make sure there is no space between upper and lower fifth wheel. If there is space, something is wrong! The kingpin may be on top of closed fifth wheel jaws; trailer would come loose very easily.
- Look into the back of the fifth wheel with caution. Make sure the fifth wheel jaws have closed around the shank of the kingpin.
- Check that the locking lever is in the “lock” position.

⚠ WARNING

MAKE SURE THE PARKING BRAKE IS ENGAGED AND THE TRACTOR CANNOT BE MOVED BEFORE PLACING ANY PART OF YOUR BODY BETWEEN THE TRACTOR AND TRAILER. TRACTOR MOVEMENT CAN CAUSE SERIOUS INJURY OR DEATH.

14. CONNECT ELECTRICAL CORD and CHECK AIRLINES

- Plug the electrical cord into the trailer and fasten the safety catch.
- Check both airlines and electrical line for damage.
- Make sure air and electrical lines will not be crushed or damaged by any of the vehicles moving parts.
- Visually inspect to see that the ABS light functions correctly when the power cord is connected. If the light stays on or comes on during use, have the ABS unit repaired at once.

15. RAISE FRONT TRAILER SUPPORTS (LANDING GEAR)

- Use low gear range (if equipped) to begin raising the landing gear. Once free of weight, switch to high gear range.
- Raise landing gear all the way up.
- After raising the landing gear fully, secure the crank handle.
- When full weight of trailer is resting on tractor, check for clearance between rear of tractor frame and landing gear.
- Check that there is enough clearance between the top of the tractor tires and the nose of the trailer.

⚠ CAUTION

NEVER DRIVE WITH THE LANDING GEAR PARTIALLY DOWN; IT COULD HANG ON RAILROAD TRACKS OR OTHER OBJECTS.



Coupling and Uncoupling

UNCOUPLING TRACTOR-SEMITRAILERS

1. POSITION RIG

- Make sure the surface of the parking area can support the weight of trailer.
- Have tractor lined up with trailer. (Pulling out at an angle can damage landing gear.)

2. EASE PRESSURE ON LOCKING JAWS

- Shut off trailer air supply to lock trailer brakes. Ease pressure on fifth wheel by backing up gently (this will help to release the fifth wheel locking lever).
- Put parking brakes on while tractor is pushing against the kingpin. This will hold the rig with pressure off the locking jaws.

3. LOWER THE LANDING GEAR

- If trailer is empty – lower the landing gear until it makes firm contact with the ground, turn crank in low gear a few extra turns; this will lift some of the weight off the tractor. (Do not lift trailer off the fifth wheel.) This will make it easier to unlatch the fifth wheel and easier to re-couple.

4. DISCONNECT AIRLINES AND ELECTRICAL CABLE

- Disconnect airlines from trailer. Connect airline gladhands to dummy couplers at back of cab or couple them together.
- Hang electrical cable with plug down to prevent moisture from entering it.
- Make sure lines are supported so they won't be damaged while driving the tractor.

5. UNLOCK FIFTH WHEEL

- Raise release handle lock.
- Pull the release handle to the "open" position.
- Stay clear of the rear of the rear tractor wheels to avoid serious injury in the event vehicle movement.

6. PULL TRACTOR PARTIALLY CLEAR OF TRAILER

- Pull tractor forward until fifth wheel comes out from under trailer.
- Stop with tractor frame under trailer (Prevents trailer from falling to ground if landing gear should collapse or sink.)

7. SECURE TRACTOR

- Apply parking brake.
- Place transmission in neutral.

8. INSPECT TRAILER SUPPORTS

- Make sure ground is supporting trailer.
- Make sure landing gear is not damaged.

9. PULL TRACTOR CLEAR OF TRAILER

- Release parking brakes.
- Check the area, then drive the tractor clear.

Accessing The Trailer Deck

Always use caution when accessing the trailer deck. Enter and leave the trailer deck only from a dock as high as the trailer floor, or by means of a ladder or stairs. Do not attempt to use items such as lights or light brackets, landing gear, or wheel-ends/tires as “footholds” when accessing the deck. The lights, brackets or other items may break or allow you to slip causing you to fall resulting in injury to you or others.

CAUTION

WALK CAREFULLY ON TRAILER DECK. USE CAUTION TO AVOID SLIPPERY CONDITIONS WHICH MAY RESULT FROM WATER, ICE, DIRT OR CARGO BEING CARRIED.

CAUTION

NEVER ATTEMPT TO STAND OR WALK ON THE TRAILER DECK WHEN THE TRAILER IS MOVING. THIS COULD CAUSE YOU TO LOSE YOUR BALANCE AND FALL FROM THE TRAILER RESULTING IN SERIOUS INJURY OR DEATH.

CAUTION

USE CAUTION WHEN ENTERING OR LEAVING DECK UNDER WET OR ICY CONDITIONS. SIDE RAILS, FRONT SKIRTS, AND TAIL SKIRTS CAN BECOME SLIPPERY RESULTING IN A FALL. FALLS FROM TRAILER DECK CAN RESULT IN SERIOUS INJURY OR DEATH.

Load Securement: Anchor Points Working Load Limits

Your Fontaine Trailer is equipped with approved anchor points for cargo Securement with each having an approved working load limit (WLL) established by Fontaine. The approved working load limits for the anchor points and Securement methods shown in the following pages describe points that are considered part of the trailer, NOT, the securing devices, such as chains, cables or straps. Securing devices must be of a sufficient design not to cut into or deform the anchor point, and be rated equal to or greater than the WLL of the trailer structure anchor point to obtain maximum published ratings.

All working load limits (WLL) pertain to standard test results performed by Fontaine Trailer Company or a qualified testing facility meeting or exceeding published regulatory requirements or industry guidelines.

Customer specified anchor points are designed for specific units and will be rated on a per customer basis.

CAUTION

ALL ANCHOR POINTS MUST HAVE A VISUAL INSPECTION PRIOR TO USE. IF AN ANCHOR POINT IS VISIBLY DAMAGED (DEFORMED, BENT, TORN, RIPPED, CRACKED OR ANY OTHER STRUCTURAL DEFECT IS FOUND) DO NOT USE IT AS AN ANCHOR POINT.

WARNING

SIDE RUB RAILS ARE NOT CONSIDERED ANCHOR POINTS AND SHOULD NOT BE USED AS SUCH.

WARNING

DO NOT EXCEED THE WORKING LOAD LIMITS OF ANY ANCHOR POINT.

Load Securement: Winch and Strap

Figures are representative of the methods used for testing standard anchor points.



Figure 1: Sliding Winch in Integral Track on Siderail
WLL = 5400 lbs. (2449 kgs)



Figure 4: "RECESSED WINCH" (Between Floor Sills)
WLL = 5400 lbs (2449 kgs)



Figure 2: Single Wrap Strap Hook Secured on Side Rail
WLL = 5400 lbs. (2449 kgs)



Figure 3: Double Wrap Strap Hook Secured on Side Rail
WLL = 5400 lbs. (2449 kgs)



The strap should go straight up and through the strap slot in the siderail as shown above. The photo at right shows an incorrect strap path. Note that in the photo at right the strap does not go straight up from the winch, but instead it angles outward to accommodate an overhanging load. **THIS IS NOT PROPER PROCEDURE AND CAN LEAD TO FAILURE, DAMAGE AND PERSONAL INJURY.** If a load extends beyond the edge of the deck you must find a safe, legal way to secure it rather than angling the strap outward from the winch.



Note that the strap in the photo above angles outward from the winch to accommodate an overhanging load. **THIS IS NOT PERMITTED.** Please see photo and caption at left for details.

Load Securement: Chain

Figures are representative of the methods used for testing standard anchor points.



Figure 1: Chain securement around stake pocket
WLL = 5400 lbs. (2449 kgs)



Figure 2: chain securement around two adjacent pipe spools
WLL = 5400 lbs. (2449 kgs)

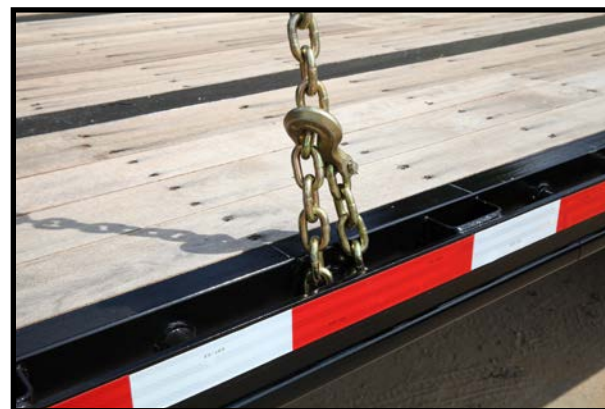

Figure 31: Chain securement around a single pipe spool
WLL = 5400 lbs. (2449 kgs)

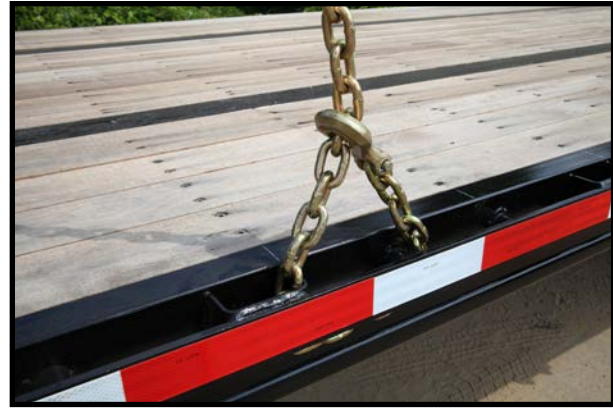

Figure 4: Chain securement through stake pocket and around pipe spool
WLL = 5400 lbs. (2449 kgs)

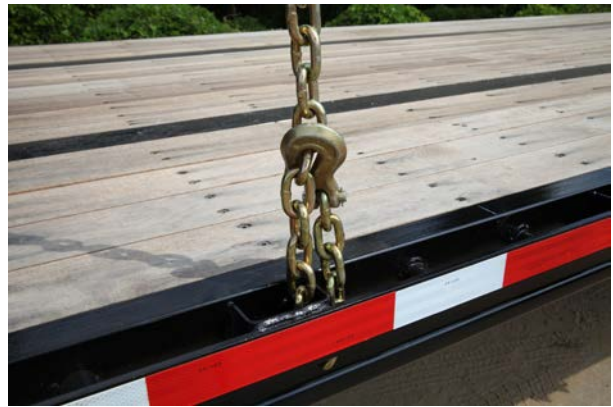

Figure 5: Chain securement through and around stake pocket
WLL = 5400 lbs. (2449 kgs)

NOTE

CHAIN TIE DOWNS HAVE THE SAME WORKING LOAD LIMIT WHETHER MOUNTED IN THE SIDE RAIL OR RECESSED INTO THE FLOOR.

WARNING

WHEN HOOKING TO A CHAIN TIE-DOWN ALWAYS HOOK BETWEEN TWO CHAIN LINKS. NEVER HOOK BETWEEN THE CHAIN TIE-DOWN CAP AND A CHAIN LINK.



Load Securement: Container Locks

LOCKING INSTRUCTIONS for
Standard Container Locks

1. Using your hand push up on the bottom of the lock assembly until it clears the upper part of the lock assembly.
2. Turn the entire inner locking assembly 90-degrees and set assembly into shallow aligning slot on top of lock.
3. Set the container on trailer using the extended assembly as a guide.
4. Turn the upper part of the locking assembly 90 degrees and lock into place.

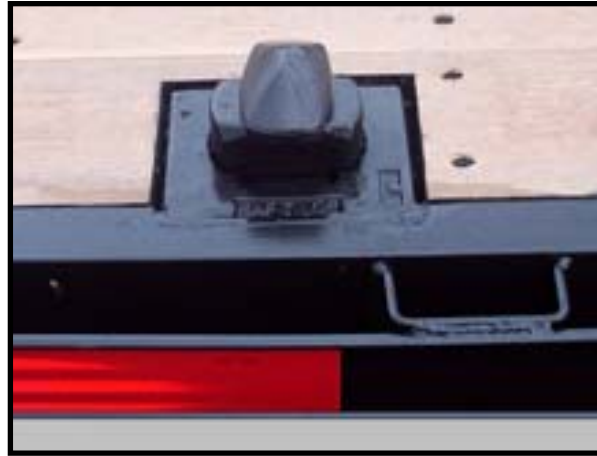

EXTENDED and LOCKED



RETRACTED



EXTENDED

⚠ WARNING

WHEN PLACING A CONTAINER ON A TRAILER **NEVER PLACE ANY PART OF YOUR BODY BETWEEN THE CONTAINER AND THE TRAILER.**

NOTE

THIS IS A REPRESENTATION OF A STANDARD CONTAINER LOCK. TYPE, STYLE AND DESIGN MAY CHANGE WITH DESIGN REQUIREMENTS, OR CUSTOMER SPECIFICATIONS.

⚠ WARNING

CONTAINER LOCKS ARE ANCHOR POINTS FOR CONTAINERS ONLY. CONTAINER LOCKS MUST BE PROPERLY EXTENDED AND LOCKED INTO CONTAINER CORNER CASTINGS BEFORE TRANSPORTING A CONTAINER. USE A MINIMUM OF 4-LOCKS PER CONTAINER.

Load Securement: Lashing Rings

NOTE

LASHING RINGS FOR STEEL SIDE RAIL MOUNT ONLY.

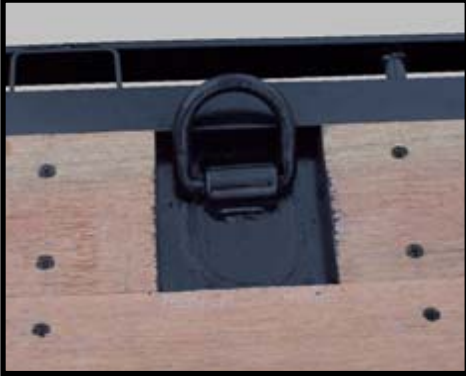

Figure – 13
“LASHING RING”
Recessed In Floor
WLL = 5400 lbs (2449 kgs)



Figure – 14
“LASHING RING”
Side Rail Mount
WLL = 5400 lbs (2449 kgs)

CAUTION

LASHING RING WORKING LOAD LIMITS ARE FOR STANDARD MOUNTINGS ONLY. WORKING LOAD LIMITS ON LASHING RINGS MAY VARY WITH DESIGN. DO NOT EXCEED STANDARD WLL WITHOUT DOCUMENTATION OF DESIGN CHANGE AND RATING.

DOT Bulkhead Securement

A Bulkhead (Header Board) is a vertical member across the front of the trailer. The Bulkhead must be secured to the trailer properly to obtain the full load rating shown on the Bulkhead nameplate. Ratings are based on FMCSA Regulations Section 393.106—Front End Structures.

The Velocity Trailer Requires a DOT Certified Wrap around Style Bulkhead Installed per the Manufacturer's Instructions.

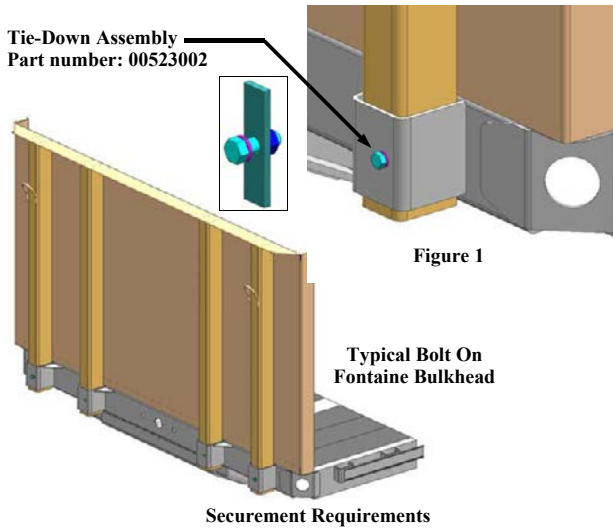

(2) Fontaine Tie-Down Assemblies, or
(2) 1/2" x 1 1/2" grade 5 hex bolts, (4) 1/2" flat washers, and (2) 1/2" hex nuts.

The Tie-Down Assemblies (or the bolts, washers and nuts) are installed one in the roadside stake pocket and the other in the curbside stake pocket.(See Figure 1)

Follow bulkhead manufacturers instructions for non-Fontaine bulkheads

⚠ CAUTION

THE BULKHEAD MUST BE SECURED BEFORE TRAILER IS TRANSPORTED. ALWAYS CHECK BULKHEAD BOLTS DURING THE PRE-TRIP INSPECTION FOR LOOSE OR BROKEN BOLTS. TIGHTEN ANY LOOSE BOLT AND REPLACE ANY BROKEN, BENT OR MISSING BOLTS.

<i>TIE-DOWN/ BOLT</i>	<i>TORQUE</i>	<i>SPECIFICATIONS:</i>
1/2" GR-5	75 FT. LB. DRY	55 FT. LB. OILED

DOT Bulkhead Securement

A Bulkhead (Header Board) is a vertical member across the front of the trailer. The Bulkhead must be secured to the trailer properly to obtain the full load rating shown on the Bulkhead nameplate. Ratings are based on FMCSA Regulations Section 393.106—Front End Structures.



Figure 1: Typical Wrap-Around Bolt-on Style Bulkhead

The Velocity Trailer Requires a DOT Certified Wrap around Style Bulkhead Installed per the Manufacturer's Instructions.

Securement Requirements

The Bulkhead Assembly must be attached to the floor/Skirt with bolts, washers and nuts across the front of the Bulkhead and secured with fasteners installed one in the roadside stake pocket and the other in the curbside stake pocket, (See Figure 2).

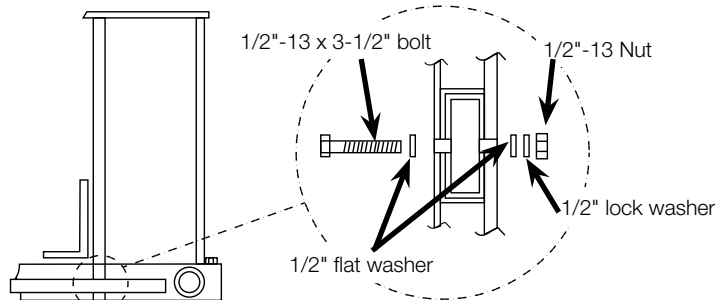

Figure 2:

Follow bulkhead manufacturers instructions for non-Fontaine bulkheads

⚠ CAUTION

THE BULKHEAD MUST BE SECURED BEFORE TRAILER IS TRANSPORTED. ALWAYS CHECK BULKHEAD BOLTS DURING THE PRE-TRIP INSPECTION FOR LOOSE OR BROKEN BOLTS. TIGHTEN ANY LOOSE BOLT AND REPLACE ANY BROKEN, BENT OR MISSING BOLTS.

<i>TIE-DOWN/ BOLT</i>	<i>TORQUE</i>	<i>SPECIFICATIONS:</i>
1/2" GR-5	75 FT. LB. DRY	55 FT. LB. OILED

Sliding Suspension Operation

⚠ WARNING

FAILURE TO LOCK A SLIDING SUSPENSION CAN CAUSE LOSS OF VEHICLE CONTROL, PROPERTY DAMAGE, SERIOUS BODILY INJURY AND DEATH. ALWAYS CHECK TO ENSURE THAT LOCK PINS ARE FULLY ENGAGED IN THE TRAILER FRAME OR SLIDER RAIL BEFORE USE.

When a Trailer is equipped with a sliding suspension follow these procedures.

1. Make sure the suspension is securely locked into place. The suspension is locked into place when the main body of each lock pin extends through the holes in the rails.



Important!! Locking Pins Must Extend Thru Holes in the Body of the Trailer Before Moving the Vehicle

2. Inspect the suspension carefully to ensure it is properly positioned and the main body of each lock pin does extend through the holes in the rails.
3. Check area around and under trailer to be clear of obstructions or personnel.
4. Apply the trailer brakes and gently rock the trailer backwards and forwards to make sure the sliding suspension is secure.

NOTE

REFERENCE THE SUSPENSION MANUFACTURER'S RECOMMENDATIONS FOR MORE DETAILED OPERATING INSTRUCTIONS, CAUTIONS AND WARNINGS.

Sliding Suspension Positioning



1. Set both the tractor and trailer brakes.
2. Turn the ball valve on the side of the slider box adjacent to the operating handle until the arrow points upward. This will set the brakes on the sliding axle and in the case of a drop deck, it will inflate the air springs until the tires clear the side rail winch track once the trailer emergency air supply is reappplied.
3. To release the lock pins:
 - A. For suspensions with manual locking pins (shown above), pull the operating handle all the way out and lock in place.
 - B. For suspensions with air assisted lock pins, activate release by flipping/pulling the labeled switch on the slide box.
4. Release the tractor and trailer brakes and allow the air springs to inflate until the tires clear the side rail winch track. Carefully drive forward or backward until the sliding suspension is at the desired location. Make sure the winch track is clear of any object that could hit the tires.
5. Release the operating handle and visually check all lock pins for locking. The main body of each lock pin must extend through the holes in the rails.
6. With the trailer brakes applied, gently rock trailer backward and forward to ensure sliding suspension is properly locked and follow proper operating procedures before pulling trailer. The lock pin must be checked at each stop to ensure each is locked.

Note: Locator bars are not used on Velocity trailers equipped with a single slider. The trailer is equipped with stops at the front and rear extremes of the slider movement.



Tire Carrier Bolt-On Type

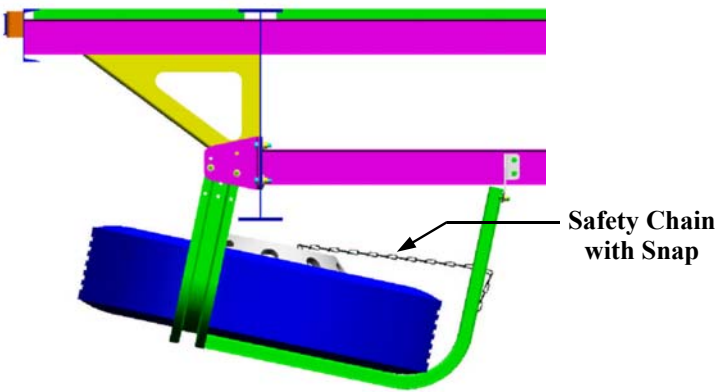
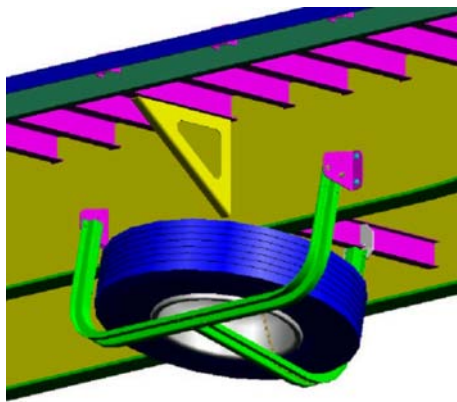

⚠ WARNING

IF SPARE TIRE IS NOT PROPERLY SECURED, IN THE CARRIER, IT CAN DISLODGE DURING TRANSIT, BECOME A PROJECTILE, AND CAUSE DEATH OR SERIOUS INJURY TO PEOPLE IN ITS PATH.

- LIMIT ONE TIRE PER CARRIER.
- TIRE MUST HAVE A DIAMETER BETWEEN 38" AND 46".
- TIGHTLY WRAP THE SAFETY CHAIN AROUND THE TIRE WITH THE END CLASP FASTENED BACK INTO THE CHAIN.
- DO NOT USE THE CARRIER IF THE CHAIN OR CARRIER IS BROKEN, DAMAGED OR MISSING PARTS.



Tire Carrier Bolt-On Type

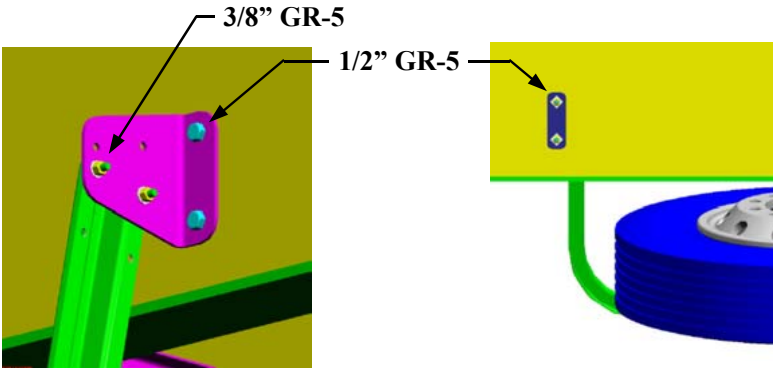

**Main Beam
Mounting Bracket**

**Main Beam Mounting Bracket
Inside of Beam**

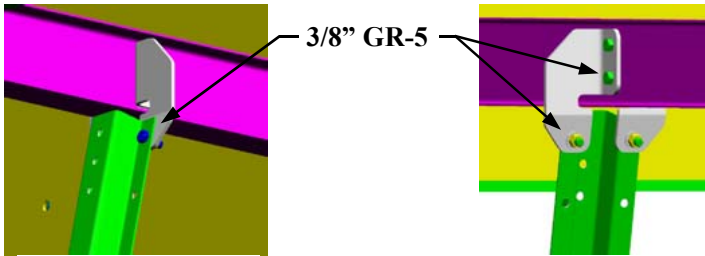

4\"/>

4\"/>

⚠ CAUTION

ALWAYS CHECK THE TIRE CARRIER BOLTS DURING THE PRE-TRIP INSPECTION FOR LOSE OR BROKEN BOLTS. TIGHTEN ANY LOSE BOLT AND REPLACE ANY BROKEN, BENT OR MISSING BOLTS.

BOLT TORQUE SPECIFICATIONS:
 3/8" GR-5 ... 30 FT. LB. DRY ... 23 FT. LB. OILED
 1/2" GR-5 ... 75 FT. LB. DRY ... 55 FT. LB. OILED

⚠ WARNING

PROPER TORQUE MUST BE MAINTAINED ON EACH BOLT THAT CONNECTS THE TIRE CARRIER TO THE TRAILER. IF THE TIRE CARRIER BECOMES LOSE FROM THE TRAILER, IT MAY FALL OFF, BECOME A PROJECTILE AND CAUSE DEATH OR SERIOUS INJURY TO PEOPLE IN ITS PATH.



Tire Storage Area Between Mainbeams

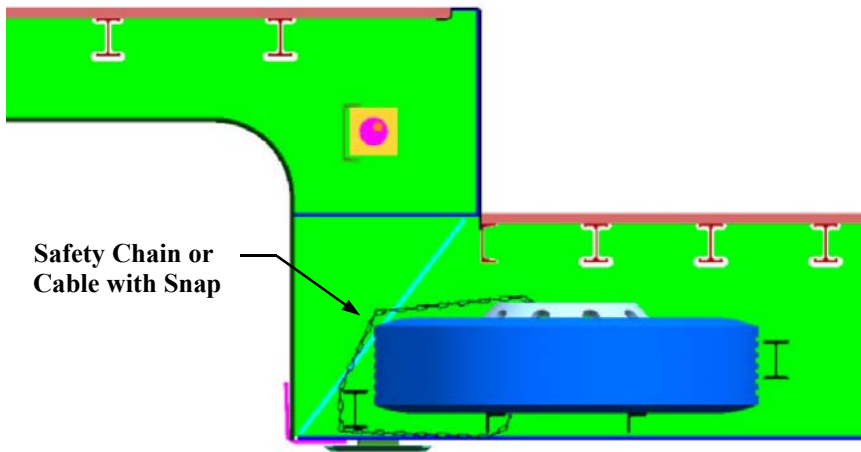

⚠ WARNING

IF SPARE TIRE IS NOT PROPERLY SECURED, IN STORAGE AREA, IT CAN DISLODGE DURING TRANSIT, BECOME A PROJECTILE, AND CAUSE DEATH OR SERIOUS INJURY TO PEOPLE IN ITS PATH.

- LIMIT ONE TIRE PER STORAGE AREA.
- TIRE MUST HAVE A DIAMETER BETWEEN 30" AND 38".
- TIGHTLY WRAP THE SAFETY CHAIN AROUND THE TIRE WITH THE END CLASP FASTENED BACK INTO THE CHAIN.
- DO NOT USE THE STORAGE AREA IF THE CHAIN IS MISSING, DAMAGED, OR BROKEN.
- SECUREMENT REQUIREMENT . . . USE MINIMUM OF 4/0 DOUBLE LOOP CHAIN, STRAP OR CABLE WITH A MINIMUM WORKING LOAD LIMIT OF 70 LBS.

Rear Unloaders

Fontaine trailers equipped with the optional rear unloader mounting package have the rear of the trailer designed to accept the Moffett M5000 or the Princeton Unloader forklifts. Always check to insure the mounting package on the trailer is appropriate for the forklift you plan to use.

Read and understand the OPERATOR'S MANUAL for the forklift you plan to use before attempting to transport it on your Fontaine Trailer. Always maintain the clearances specified by the forklift manufacturer.

Trailers with the rear unloader kit installed are required to have a **Rear Impact Guard** which complies with N.H.T.S.A. Articles 571.223 and 571.224. Your Fontaine Trailer is equipped with a hinged bumper tube that has been tested to ensure compliance with the rear underguard regulations. When hauling a forklift, the tube will swing out of the way to allow the lift to be installed.



FONTAINE FORKLIFT HAULER KIT

CAUTION

DRIVING OVER ABRUPT DROP-OFFS AND STEEP INCLINES MAY DAMAGE THE LIFT TRUCKS REAR WHEEL. FOLLOW ALL INSTRUCTIONS IN THE LIFT TRUCK OPERATOR'S MANUAL TO AVOID SERIOUS INJURY.

WARNING

DON'T RISK SERIOUS INJURY OR DEATH FOLLOW THESE INSTRUCTIONS

- READ AND UNDERSTAND THE FORKLIFT OPERATOR'S MANUAL BEFORE ATTEMPTING TO TRANSPORT IT.
- READ, UNDERSTAND AND FOLLOW ALL SAFETY SIGNS ON THE FORKLIFT.
- ALWAYS PARK TRAILER IN A POSITION TO PERMIT SAFE LOADING AND UNLOADING OF THE FORKLIFT.
- SAFETY CHAINS AND BINDERS MUST BE IN PLACE AND SECURE WHEN TRANSPORTING THE FORKLIFT.
- DO NOT PUT ANY PART OF YOUR BODY BETWEEN THE FORKLIFT AND THE TRAILER.
- OPERATE THE FORKLIFT CAREFULLY WHEN LOADING AND UNLOADING. KEEP PEOPLE AWAY.
- DO NOT ALLOW PEOPLE OR PARTS OF THE BODY UNDER THE FORKLIFT.
- LOWER FORKS IMMEDIATELY AFTER UNLOADING FORKLIFT FROM THE TRAILER.

NOTE

IN ORDER TO MAINTAIN COMPLIANCE WITH FEDERAL REGULATIONS FOR REAR IMPACT GUARDS, THE BUMPER TUBE MUST BE POSITIONED AS SHOWN IN FIGURE B WITH THE LOCK PIN IN PLACE WHEN THERE IS NO FORKLIFT INSTALLED ON THE TRAILER.



Figure A: Bumper tube positioned to allow forklift to be loaded.

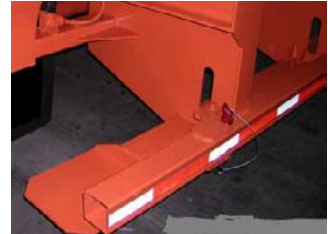

Figure B: Bumper tube positioned for trailer operation with no forklift.

NOTE

PHOTOS FOR REFERENCE ONLY

WARNING

BEFORE ATTEMPTING TO TRANSPORT A FORKLIFT:

1. HITCH PINS MUST BE INSTALLED IN HANGER PLATES (IF APPLICABLE).
2. SAFETY CHAINS MUST BE CONNECTED.
3. ELECTRICAL CONNECTOR (7 PIN) MUST BE CONNECTED.



Routine Maintenance

AIR BRAKE MAINTENANCE

Successful maintenance of the air brake system depends upon systematic inspection and repair at regular intervals. The length of these intervals depends upon the trailer operation and mileage.

Adjustments, inspections and minor repairs that can be performed by the operator are listed below. These procedures must include immediate replacement of all worn or damaged parts.

RESERVOIR TANK

The first requirement in an air brake system is clean air at proper pressure. The operator must open the drain cock on the underside of the reservoirs until all moisture has escaped.

Drainage should be done periodically to remove water and sludge from the system. This is especially important in cold weather to forestall freezing and obstruction of the lines and valves. Each tank must be drained completely to insure removal of condensation. After removing moisture, close the drain cock and inspect reservoirs for looseness or damage. Make sure all connections are tight and brake lines are properly supported.

GLADHANDS

Inspect gladhands to insure proper operation without obstructions. With the trailer connected to the truck tractor and air in the system, coat the gladhands and mounting with soapsuds to make sure there is no leakage. Be certain gladhands seals are in good condition and not saturated with grease, oil or other foreign material. We recommended annual replacement of gladhands seals.

BRAKE TUBING, LINES, FITTINGS & HOSES

Visually inspect brake lines and hoses for loose connections, chafing, cracks, breaks, cuts, bruises, broken-out sections and deterioration. Replace immediately upon first sign of the above. Exercise extreme caution when working or welding around nylon tubing, if so equipped. It is recommended that tubing in areas where welding operations are performed be removed prior to welding operations and reinstalled after welding is completed. If tubing removal is not practical, the tubing must be shielded from welding sparks and/or heat damage.

SERVICE AND SPRING BRAKE CHAMBERS

Visually check air chamber clamp bands and mounting nuts for tightness. Torque chamber mounting nuts 75 to 100 ft. lb. Check chambers for damage or dents and sign of leaks.

AIR VALVES

Inspect all air valves for leaks. If excessive leakage is found, the valve must be repaired or replaced. We recommend that air valves be replaced when neces-

CAUTION

DISASSEMBLY AND REPAIR OF ANY SPRING BRAKE IS A DANGEROUS AND COMPLEX TASK THAT SHOULD NOT BE UNDERTAKEN BY AN INEXPERIENCED MECHANIC. SPECIAL TOOLS AND INFORMATION ARE REQUIRED IF SERIOUS PERSONAL INJURY IS TO BE AVOIDED. REFER THESE REPAIRS TO YOUR FONTAINE DEALER.

sary with new or rebuilt valves. Replacement maintenance and seal kits are available from Your FONTAINE Dealer. Call 1-800-821-6535 for the FONTAINE Service Center and dealer nearest you. Inspect brake drums. Any accumulation of mud, dirt or rust on the drums should be removed. Any broken or cracked drums should be removed from service.

BRAKE LINING

Inspect and check the brake lining thickness. Brake lining must be replaced if excessively worn or if coated with oil, grease, or foreign material.

Call 1-800-821-6535

For Fontaine Service Center And Dealer Nearest You

Website: www.fontainetrailer.com



Basic Maintenance Schedule

Frequent inspection and preventative maintenance are important in the life of any machine. Your FONTAINE trailer is no exception. Proper care and maintenance will protect the long life of your trailer and may eliminate unnecessary repair costs and downtime.

DAILY INTERVALS (PRE-TRIP INSPECTION)

Drain Moisture:

Drain the moisture from air reservoir daily by opening the drain cock on underside of reservoir. Leave the drain cock open until the moisture disappears. After all moisture has escaped, close the drain cock or moisture trap.

Inflate Tires:

Check tire pressure daily or every 3000 miles. Remove all objects lodged between treads or carcasses or from between duals. Refer to the Tire Manufacturers Load/Inflation pressure settings for your applicable tire size.

Tighten Mounting Nuts:

Check that all wheel and hub mounting nuts are present and secure. If marked after torquing, insure the torque identification mark has not moved.

Wheel-ends:

Visually inspect the hubcap and around the wheel seal for lubrication leaks.

Adjust Brakes:

Check the travel of brake chamber push rod and adjust brakes if necessary. Push rod travel should be kept at a minimum of 1/2" without brakes dragging. Pushrod travel should not exceed 2".

Check Lights:

Open and close trailer light switches to see if lamps respond properly. Clean all lights and warning reflectors. Make sure the ABS system is operating properly.

Check Tools & Equipment:

Check the tools, flares and other equipment to make certain all are present and in good condition. This inspection should become a daily habit. Minor repairs or adjustments depend to a great extent upon the tools and equipment carried on the trailer.

MONTHLY INTERVALS

Inspect Hose Assemblies & Gaskets:

Inspect all hose assemblies and gladhand coupling gaskets for abrasions, swelling, or other damages. Replace as necessary.

Check Brake Linings:

Check the brake lining thickness. Brake lining should be replaced when the lining thickness approaches the wear line indicator built into the lining or when the thickness is at 1/4".

Inspect Reservoir & Brake Lines:

Inspect reservoir for looseness or damage. Make certain all connections are tight, and that brake lines are properly supported so as not to chafe on other trailer parts.

Check Electrical System:

Inspect lights, wiring, and coupling sockets. Secure loose wires.

Tighten Assembly, Screws & Nuts:

Tighten all wheel hub mounting nuts, spring clips, and U bolts.

Measure and check all tires:

Measure and check all tires for proper mating and un-serviceable condition. Serviceable tires which indicate abnormal wear should be rotated to other wheel positions. Apparent mechanical defects should be corrected.

Check Axle Alignment:

Check the axle for proper alignment. This deficiency is the most probable cause of tire wear.

Inspect & Clean Under Side of the Trailer:

Clean out all objects lodged in the under-construction including the suspension area. For mechanical spring systems, inspect springs, bushings, and hangers for cracks or excessive wear. Check all hanger bolts, "U" bolts and other adjustable points. For air ride systems, check air springs, and shocks for wear or damage. Check the suspension rubber bushings and wear washers to make certain they are in good condition.

SIX (6) MONTH INTERVAL

Check structure for cracks in welds or steel. Check for any other structural damages. Fontaine Commercial / Fontaine PartSource should be consulted for repair instructions.



Lubrication Notes

1. **Coupler & Kingpin:** Clean all sand, grit and other foreign matter from coupler base. With a hand paddle, coat the machined surface of coupler base pickup ramps and edge of coupler hook. Place a light film of grease on the side surface of kingpin. Lubrication Interval – every 5,000 miles
2. **Cam Bearing:** Lubricate sparingly with grease gun. Excessive lubrication will force lubricant into internal brake parts causing faulty brakes. Lubrication Interval – every 10,000 miles
3. **Wheel Ends:** Most Fontaine Trailers are Equipped with Hendrickson RTR suspensions equipped with five (5) year wheel end warranty. The typical lubrication for these wheel ends is Chevron Delco SF grease. If no leakage is noticed in the first 5 years of service, no wheel end lubrication maintenance is required. Units with sight glasses in the hubcaps with removable plugs use mineral based Hypoid Oil S.A.E. 80/90. **NOTE:** On units with oil seals, change oil and seals every 100,000 miles.
4. **Brake Shoes:** Place several drops of oil on inner and outer end of brake shoe where anchor pins pass through the shoe. Place bar between spider and brake shoe, and lift the cam end of shoe off cam. Lubricate with several drops of oil on brake shoe roller and rotate roller to new contact point. Lubrication Interval – every 10,000 miles
5. **Cam:** When wheels are removed, place a light film of grease on top and bottom surface of S cam. **CAUTION: DO NOT ALLOW GREASE TO COME IN CONTACT WITH BRAKE LINING.**
Lubrication Interval – every 10,000 miles

Basic Trailer Maintenance

NOTE

THE INFORMATION PROVIDED IN THIS SECTION IS INTENDED TO PROVIDE SUGGESTED BASIC MAINTENANCE PROCEDURES. REFER TO THE VENDOR COMPONENT SUPPLIER'S INFORMATION FOR MORE DETAILED MAINTENANCE INSTRUCTIONS.

KINGPIN AND FIFTH WHEEL AREA

Inspect the kingpin for excessive wear, rough edges, looseness, broken or chipped out areas and cracks. Any kingpin showing such condition must be replaced at once. Do not, under any circumstance, weld the kingpin to compensate for wear. Once a kingpin has been heated its physical characteristics are changed and its subsequent performance cannot be predicted. Contact Fontaine Trailer Company Customer Service for proper replacement services.

Check and inspect the fifth wheel area for cracks or breaks and for secure attachment to the trailer. Any welding performed in this area is to be restricted to those welds specified by Fontaine and is to be performed in the manner prescribed by Fontaine.

NOTE

FONTAINE RECOMMENDS THAT ONLY AN AUTHORIZED FONTAINE DEALER PERFORM REPAIRS IN THE KINGPIN AREA.

REAR IMPACT GUARDS

Your new Fontaine Trailer has been designed & tested to meet the requirements of N.H.T.S.A. article 571.223 and 571.224.

The rear bumper should be checked during regular maintenance for cracks, bonds & etc. If repair is needed, please refer to T.M.C. Recommended Practice 732 (T).



Leaf Type Springs Care And Maintenance

The leaf springs in a heavy duty truck/trailer suspension are working, flexible components and the main load supporting members in the assembly. They cushion the vehicle and its load from various road shocks and provide the necessary stability to resist roll-over, brake and drive forces. A reasonable amount of care and maintenance is required to provide a satisfactory service life.

The spring stack must be tightly clamped to its spring seat and the axle to prevent any movement between the U-bolts. This area is a dead zone and all flexing must take place between the U-bolts and the dead ends of the springs. Therefore, it is important the spring U-bolts be checked for proper tightness once or twice during the first few months of service, until such time as the spring leaves wear-in with usage. Thereafter, they should be checked periodically as a matter of normal maintenance.

One or more broken spring leaves near or through the center bolt hole, indicates a loose U-bolt condition which has permitted excessive flexing in the clamp area. Failure to keep the U-bolts tight can also cause sheared spring center bolts, broken U-bolts, or rounding of the axle spring seat.

A broken spring leaf adjustment to or outside the U-bolt clamp area indicates either there has been an over-loaded condition or the spring assembly is nearing the end of its service life. Single and multi-leaf springs on trucks and trailers should be closely inspected at regular intervals for signs of such failure. Broken leaves in a multi-leaf pile should be replaced immediately to prevent over-loading the remaining leaves. Better yet, the complete spring stack should be replaced. If just the broken leaf is replaced, other leaves in the stack will break in a short length of time.

Springs exhibit a finite (limited) service life. Failures can be expected from normal fatigue after a responsible service use.

In suspensions using the vari-rate springs and frame brackets, the wear pads and main spring leaves should be checked periodically for excessive wear. Replacement wear pads are available for most suspensions, and it may be necessary to install them long before the main leaf requires replacement. Excessive wear at these load contact points eliminates the vari-rate effect resulting in a rough ride. If these load bearing points are left unattended, wear can progress to the point where a complete frame hanger replacement will be necessary. In some instances, an occasional dab of grease at these points will greatly reduce the fretting and wearing away of the wear pads and main spring leaf.

SERVICE TIPS

To obtain maximum service life from a spring assembly the following steps should be followed:

1. Before placing trailer in service, torque all U-bolts evenly to manufacturer's recommendation.
2. Retorque at 3,000 miles and every 3 months thereafter.
3. Broken spring leaves between the U-bolts indicates loose U-bolts. Replace broken leaves at earliest opportunity and lubricate the U-bolt threads before tightening.
4. Spring leaf failures outside U-bolt area are an indication of:
 - a. Repeated overload.
 - b. Spring assembly has completed its normal life cycle. In either case the entire spring assembly should be replaced.
5. On vari-rate spring suspensions, periodically apply lubricant between the spring assembly and hangers to obtain maximum service life.

Wheel and Rim Care

Standard wheel material on your Fontaine trailer is aluminum or steel disc wheels. Wheel nuts are inspected and tightened to specifications at the factory and must be checked again at pre-delivery. To maintain the correct torque on the wheels of a new trailer the nut torque must be checked periodically. During normal highway operation of a new trailer, this check should be made at the first 100, 500, and 1,000 miles and every 5,000 miles thereafter. Severe service conditions may require more tightening. Loose wheel nuts may cause shimmy, uneven tire wear, and vibration. Elongated stud holes in the wheels may result from loose hub nuts. Wheel and hub nuts must be torqued to proper specifications to provide maximum service life.



How To Service And Install Wheel Bearings

Wheel bearing life depends on three things: (1) Proper lubrication; (2) Cleanliness; and (3) Proper adjustment. Trailer axle bearings are normally provided with wheel seals which require only keeping the lubrication at the proper level. Whether installing new bearings or servicing a trailer in the shop, here are the steps to follow.

Remove the wheel hub and bearing cones. Clean all the old grease from wheel hub, bearing cones, and hub cap with kerosene or diesel fuel oil (not gasoline and not in hot solution tank or with water-alkaline solutions). Use a stiff fiber brush, but not a steel or brass wire brush. Dry the parts with a clean absorbent cloth or paper. Compressed air can be used to dry the bearing only if the air is filtered, since water in the air line can cause rusting. Also clean and dry the hands and tools, since grease will not adhere to a surface wet with solvent. If bearings are not to be used soon, pack with wheel bearing grease and wrap in clean wax paper. Don't lay clean bearings on floor or dirty workbench.

INSPECT FOR DAMAGE

While the bearing is clean and free of grease, inspect it for signs of wear or damage. Excessive wear caused by abrasive dirt is the most common cause for premature bearing failure. This can be recognized by a dull appearance to the rollers and raceways; they may feel rough or show pit marks or indentations. Flaking or spalling on the small end of the rollers on their corresponding cup and cone rolling surfaces is caused by improper loose adjustment. Spalling or excessive wear at the large end of the rollers indicates an overly tight adjustment.

Fractures or fine hairline cracks across the cup or cone may be caused by forcing a cone assembly on an oversize spindle, or forcing a cup into warped hub bore, or by a cocked cup or a cocked cone. Brinelling (a series of lines or indentations on the raceways spaced to a definite pattern) indicates a driving force has squeezed the bearing and damaged the rollers and raceways. This can be caused by improper mounting practices or by sudden excessive shock loads.

Corrosion or its pock-marks on the raceways and rollers, resulting from water getting into the lubricant, can be caused by a worn or damaged grease seal, or by handling the bearing with moist hands, or by an improper type of lubricant. Overheated bearings have a blue or brown-blue discoloration, and definitely indicate that the bearing metal has been damaged. This can be caused by dirt, lack of lubricant, excessive friction, or over adjustment (too tight).

Be sure to check the bearing cone for wear and pits. After the bearing is clean, hold it up so that the bearing is between the eye and the light. Look between the rollers so that the raceway or outer surface of the cone can be seen. Holding the cage, rotate the cone to check for pits over its entire outer surface.

Replace bearings if any of these conditions exist. Also replace worn or damaged grease or oil seals. Always replace a seal if it has been removed from the axle. Be sure to grease the lip of the grease seal before sliding it on the axle. Check the condition of the hub and axle spindle, and remove any nicks or burrs which might prevent proper seating.

The bearing cup must fit tightly in hub. This must be a press fit. Use an arbor press to install the cup in the hub, checking to make sure that it is square and completely bottomed. If an arbor press is not available, use an old bearing cup as a driving tool and tap it lightly with a hammer. Never strike the narrow section of a cup directly with a hammer, since this can chip or crack the case hardened surface.

ADJUSTMENT OF BEARINGS

There have been many changes in the spindle nuts being used on trailer axles. The new designs have changed the method required to properly adjust the bearings. While many wheel end systems still use the old three (3) piece system, there are inherent differences even in this system depending on the source for the spindle nuts. Adjustment of bearings requires a full understanding of the different spindle nut systems offered and where to find the correct adjustment procedure. Feel free to contact Fontaine PartSource, a Fontaine dealer or the OEM factory for help in determining the system on your trailer.



How To Service And Install Wheel Bearings

Some links to popular websites pertaining to trailer axle and suspension information including wheel end adjustment procedures are shown below. Copy the link into your web browser to access recommended adjustment procedures:

Hendrickson International: www.Hendrickson-intl.com

Arvin Meritor: www.Meritor.com

Stemco Bearing Adjustment Procedure

<http://www.stemco.com/wp-content/uploads/2011/12/STEMCO-BearingAdjust-571-2902-WEB.pdf>

Hendrickson Poster – Precision Nut System

<http://www.hendrickson-intl.com/getattachment/501103c4-c552-4c77-98b9-bc-cb0786f5da/T71005-PRECISION-NUT-SYSTEM-Installation-Procedu.aspx..pdf>

Hendrickson Standard Wheel end Maintenance

<http://www.hendrickson-intl.com/CMSPages/GetFile.aspx?guid=e492c099-b370-40b4-bb42-55e20a224b8d>

Hendrickson HXL3 Wheel end Maintenance

<http://www.hendrickson-intl.com/CMSPages/GetFile.aspx?guid=12294fbf-0056-44f0-a907-40e50d76fdce>

Hendrickson HXL5 Wheel end Maintenance

<http://www.hendrickson-intl.com/CMSPages/GetFile.aspx?guid=ab72b69c-5038-4670-809d-7f8579831179>

Hendrickson HXL7 Wheel end Maintenance

<http://www.hendrickson-intl.com/CMSPages/GetFile.aspx?guid=7f042c45-39ae-49ea-aa6f-4ff9b7af5771>

Adjustment Info can also be found in the TMC Recommended Practices

RP618A

&

RP622A

CAUTION

DISASSEMBLY AND REPAIR OF ANY WHEEL END IS A COMPLEX AS WELL AS A SAFETY RELATED TASK THAT SHOULD NOT BE UNDER TAKEN BY AN INEXPERIENCED MECHANIC. SPECIAL TOOLS AND INFORMATION ARE REQUIRED. REFER THESE REPAIRS TO YOUR FONTAINE DEALER.

Wheel Installation and Maintenance

Disc Wheel Mounting Instructions for 6 & 10 Stud Hubs with BALL SEAT Mounted Disc Wheels.

Rims must be correctly assembled, using the correct capnuts and must be correctly aligned to assure maximum service life and maximum safety.

1. All parts must be clean, free of rust, dirt or paint.
2. Position the inner wheel over the studs being careful not to damage the threads.
3. Install inner capnuts and tighten to 50 FT. LBS. in the sequence shown

Then tighten to full torque using the same sequence

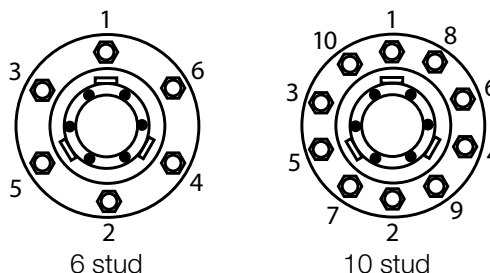

Thread Size	Torque
Standard Capnut 3/4-16 and 1-1/8-16	450-500 Ft. Lbs.

CAUTION

THE TORQUE LISTED IS FOR DRY THREADS WITH NO LUBRICANT. PROPER CAPNUT TORQUE IS IMPORTANT. INSUFFICIENT TORQUE CAN CAUSE STUD BREAKAGE AND DAMAGE. OVER TORQUE CAN OVER STRESS THE STUDS AND STRIP THE THREADS.

Wheel Installation and Maintenance

4. Position the outer wheel over the inner capnuts being careful not to damage the threads.
5. Install the outer capnuts and tighten to 50 FT. LBS. in the sequence shown in Step 3. Then tighten to full torque using the same sequence.
6. After the first 50 to 100 miles of service the capnut torque should be rechecked.
 - A. Loosen the outer capnuts.
 - B. Check the torque of the inner capnuts in the tightening direction.
 - C. Tighten the outer capnuts to 50 FT. LBS. in the sequence shown if Step 5. Tighten to full torque using the same sequence.
5. After the first 50 to 100 miles of service the capnut torque should be retightened to 500-550 ft. lbs.
6. Make sure the surface on the disc wheel, which is contacted by the flange nuts is flat.
7. Disc wheel mounting surfaces should not have more than 1-1/2 Mil. Thickness of paint. Excessive paint thickness can cause loose disc wheels.

Disc Wheel Mounting Instructions for 8 & 10 Stud Hubs with HUB PILOTED Disc Wheels.

1. All parts must be clean, free of rust, dirt or paint.
2. Position the inner wheel over the studs being careful not to damage the threads.
3. Position the outer wheel over the studs being careful not to damage the threads.
4. Install flange nuts and tighten to 50 FT. LBS. in the sequence shown

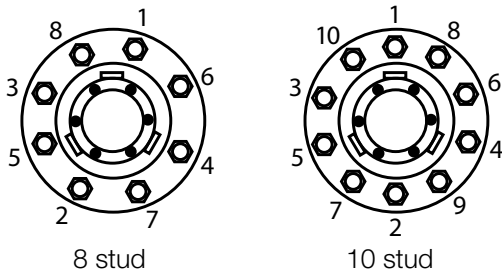

Then tighten to full torque using the same sequence.

Thread Size	Torque
M-22 x 1.5	500-550 Ft. Lbs.

CAUTION

THE TORQUE LISTED IS FOR DRY THREADS WITH NO LUBRICANT. PROPER CAPNUT TORQUE IS IMPORTANT. INSUFFICIENT TORQUE CAN CAUSE STUD BREAKAGE AND DAMAGE. OVER TORQUE CAN OVER STRESS THE STUDS AND STRIP THE THREADS.

CAUTION

BEFORE INSTALLING TWO PIECE CONE LOCK CAPNUTS, LUBRICATE THE CONTACT SURFACES BETWEEN THE CAPNUT AND WASHER WITH SAE30W OIL. THIS WILL MINIMIZE CORROSION BETWEEN THE MATING SURFACES. WHEEL STUDS ON HUBS OF VEHICLES UTILIZING THE HUB-PILOTED WHEEL SYSTEM HAVE RIGHT-HAND THREADS.



Self Adjusting Slack Adjuster

OPERATIONAL CHECK

Trailers equipped with Drum Brakes utilize slack adjusters to control the relationship of the brake lining relative to the brake drum surface to minimize spring-brake pushrod stroke and maximize braking power.

It is important to ensure the slack is properly adjusted prior to each trip.

Functional operation of the slack adjuster can be performed on the vehicle by:

1. Block wheels to prevent vehicle from rolling.
2. Check that the push rod is fully retracted; apply air to release spring brake.
3. Manually de-adjust brakes (turn adjustment hex counterclockwise) to create an excessive clearance condition. (A ratcheting sound will occur)
4. Make a full service brake application, on release; allow sufficient time for brake to fully retract. During the brake release, observe rotation of the adjustment hex (attaching a wrench on the hex will make this rotation easier to see). This rotation indicates that an excessive clearance condition has been determined by the slack adjuster, and it is making an adjustment to compensate. On each subsequent brake release the amount of adjustment and pushrod travel will be reduced until the desired clearance is achieved.
5. Refer to the Slack Adjuster manufacturer's literature for more detailed information and proper pushrod stroke requirements.



NOTE

REFER TO THE SLACK ADJUSTER MANUFACTURER RECOMMENDATIONS FOR COMPLETE DETAILS ON MAINTENANCE, INSPECTION AND TROUBLESHOOTING OF THIS COMPONENT.

LUBRICATION

The Self-Adjusting Slack Adjuster should be lubricated in conjunction with the lubrication prescribed for vehicle chassis. The lubrication interval should not, however, exceed 10,000 miles or 3 months. No special grease is required, however the use of moly-disulphide loaded grease or oil is not recommended since

it may lower friction capabilities in the adjusting clutch parts, and decrease automatic adjustment reliability.

INSPECTION

1. During normal lubrication intervals, visually inspect slack adjuster and anchor bracket for damage. Check that anchor bracket is tight and the control arm is in its "Full Release" position (refer to manufacturer literature).
2. Maintaining proper brake adjustment and brake balance cannot be accomplished by the slack adjuster alone. The condition of foundation brake components has a direct bearing on the effectiveness of brake adjustment; therefore, periodic inspection of these components is necessary.
 - a. BRAKE CHAMBERS
Check that brake chamber mounting bolts are tight and proper alignment is maintained to avoid interference between chamber pushrod and chamber housing. Verify that the brake chamber pushrod length is equal on opposing brake chambers of the same axle.
 - b. CAMSHAFT BUSHINGS
Optimum brake adjustment cannot be achieved when worn bushings are used
 - c. WHEEL BEARING ADJUSTMENT
Accurate wheel bearing pre-load is necessary to maintain proper alignment between the brake drum and brake shoes.

MAINTENANCE

During normal chassis lube, adjusters should be inspected for damage. Check anchor brackets to ensure that they are tight.

During reline, check the de-adjustment torque. Place a torque wrench on the 7/16" adjusting hex. Turn the torque wrench counterclockwise and check that the clutch does not slip at a torque less than 13 Ft. Lbs. A ratcheting sound will occur while backing off. If clutch slips at a lesser torque, the adjuster must be replaced.

Tips for Prolonged Brake Drum Life

1. Allow periodic cooling off stops when operating in mountainous terrain but do not set brakes when drums are extremely hot. Park on level ground, in gear for cooling-down period.
2. If possible, avoid water pockets in road that may drench red hot drums and cause cracking.
3. Do not favor tractor or trailer brakes at the expense of other. This reduces braking action of the unit and places a severe burden on the brake components doing the work.
4. Periodically inspect valves, linings, drums, cams and other brake parts to see that they are properly adjusted and in good working order.
5. Replace bent or distorted brake shoes immediately.
6. Replace worn brake linings before the bolts or rivets have a chance to score the drums.
7. Remove small stones or foreign matter that may occasionally get inside drums.
8. Consult reputable brake lining specialists for recommended makes and grades of lining that will prolong drum life.
9. Make sure tractor-trailer units have an adequate ratio of surface lining area to gross vehicle weight.
10. Do not overload.
11. Balance loads wherever possible to maintain uniform axle-load and therefore brake-drum distribution.
12. Use brake drums of adequate weight and thickness for unusual or severe applications.
13. Practice safe, sensible driving habits.

Tire Maintenance

INFLATION PRESSURE

The most critical factor in tire maintenance is proper inflation. No tire or tube is completely impervious to loss of air pressure. To avoid the hazards of under inflation, lost air must be replaced.

Driving on any tire that does not have the correct inflation pressure is dangerous and will cause tire damage.

Any under inflated tire builds up excessive heat that may result in sudden tire destruction. The correct inflation pressures for your tires are a function of many factors including: load, speed, road surface and handling. Consult your tire dealer for the proper inflation pressures for your application.

Check inflation pressures on all your tires at least once a week, including spares.

CAUTION

FAILURE TO MAINTAIN CORRECT INFLATION PRESSURE MAY RESULT IN SUDDEN TIRE DESTRUCTION, IMPROPER VEHICLE HANDLING, AND MAY CAUSE RAPID AND IRREGULAR TIRE WEAR. THEREFORE, INFLATION PRESSURES SHOULD BE CHECKED WEEKLY AND ALWAYS BEFORE LONG DISTANCE TRIPS.

Pressure should be checked when tires are cold, before they have been driven over the road. The ideal time to check tire pressures is early morning. Driving, even for a short distance, causes tires to heat up and air pressures to increase.

Never bleed air from hot tires as your tires will then be under inflated. Make sure to check both tires in a dual fitment. Pressures should be the same.

For optimum tire performance it is usually best to use the tire inflation pressure recommended by the tire manufacturer for the particular axle load. Exceeding this pressure could result in reduced traction and tread life.

Tire Maintenance

TIRE INSPECTION

While checking inflation pressures, it is a good time to **INSPECT YOUR TIRES. ANY TIME YOU SEE ANY DAMAGE TO YOUR TIRES OR WHEELS/RIMS, SEE ANY OF YOUR TIRE DEALERS AT ONCE.**

Before driving, inspect your tires, including the spare, and check your air pressures. If your pressure check indicates that one of your tires has lost pressure of four pounds or more, look for signs of penetrations, valve leakage, or wheel/rim damage that may account for air loss.

Always examine your tires for bulges, cracks, cuts or penetrations. If any such damage is found, a Tire dealer must inspect the tire at once. Use of a damaged tire could result in tire destruction, property damage and personal injury.

DRIVE CAREFULLY

All tires will wear out faster when subjected to high speeds as well as hard cornering, rapid starts, sudden stops and frequent driving on surfaces that are in poor condition. Surfaces with potholes or rocks and other objects can damage tires and cause vehicle misalignment. When you drive on such surfaces, drive on them carefully and slowly, and before driving at normal or highway speeds, examine your tires for any damage, such as cuts or penetrations.

DO NOT OVERLOAD

The maximum load that can be put on a truck tire is dependent upon the speed at which the tire will be used. Consult your Tire dealer for complete information on the allowable loads for your tires in your application. Tires that are loaded beyond their maximum allowable loads for the particular application will build up excessive heat that may result in sudden tire destruction, property damage and personal injury.

Do not exceed the gross axle weight ratings for any axle on your vehicle.

DRIVE AT PROPER SPEEDS

The maximum speed at which tires can be operated is indicated in the tire manufacturer's data book. This speed varies for each type of tire and depends on the type of application. Consult your Tire dealer for assistance in determining the maximum speed for your application. You should not exceed reasonable speeds indicated by the legal limits and driving conditions.

CAUTION

EXCEEDING THE MAXIMUM SPEED FOR VEHICLE YOUR TIRES IS RATED CAN RESULT IN SUDDEN TIRE DESTRUCTION, PROPERTY DAMAGE AND PERSONAL INJURY.

WHEN DRIVING AT HIGHWAY SPEEDS, CORRECT INFLATION PRESSURE IS ESPECIALLY IMPORTANT. However, at these speeds, even with correct inflation pressures, a road hazard, for example, is more difficult to avoid and if contact is made, has a greater chance of causing tire damage than at lower speed. Moreover, driving at high speed increases the possibility of an accident as a greater distance is required to bring your vehicle to a safe stop.

BALANCING

Under normal conditions, truck tires do not need to be balanced. Common practice is to check tire balance if a ride complaint is made by the driver. Before removing the tire-wheel assembly from the vehicle, check for radial and lateral runout. Bent wheels and rims or improper mounting can cause excessive runouts. If balance is still required, a simple static balance with bubble balance or a wall mounted axle bearing and hub type gravity balance should be sufficient.

ROTATION

Tires should be rotated only when necessary. If the tires are wearing evenly, there is no need to rotate. If irregular wear becomes apparent or if the wear rate on the tires is perceptively different (from axle to axle), then the tires should be rotated in such a manner as to alleviate the conditions.

Tire Maintenance

STORAGE

All tires should be stored in a cool dry place indoors so that there is no danger of water collecting inside them. Serious problems can occur with tube-type tires when they are mounted with water trapped between the tire and tube. Due to pressurization, the liquid can pass through the inner liner and into the casing plies.

This can result in sudden tire failure. Most of the problems of this nature have been due to improper storage that allowed water to enter the casing. This is a particular problem with tube-type tires because of the difficulty in detecting water that collected between the tire and tube. When tires are stored, they should be stored in a cool place away from sources of heat and ozone such as hot pipes and electric generators. Be sure tires do not contact surfaces which could deteriorate the rubber. TIRES EXPOSED TO THESE SUBSTANCES COULD BE SUBJECT TO SUDDEN FAILURE.

RECOMMENDATIONS FOR THE USE OF DYNAMOMETERS

Severe damage can result in the crown area of radial truck tires when run on dynamometers for extended periods. Quite often the damage is internal and not discovered until after the vehicle has been put back in service.

PROPER MOUNTING ON VEHICLE

When wheel assemblies are mounted on a vehicle, be sure that the valves do not touch the brake drums or any mechanical part of the vehicle.

Tires mounted in duals must be matched so that the maximum difference between the diameters of the tires does not exceed 1/4 inch or a circumferential difference of 3/4 inch. Failure to properly match dual tires will result in the tire with the larger diameter carrying a disproportionate share of the load, which can cause sudden tire destruction.

DUAL SPACING

It is also important that sufficient space is provided between dual tires to allow air to flow and cool the tires and to prevent the tires from rubbing against one another.

To make sure dual spacing is correct, simply measure the two tires from center to center of the tread, and refer to the minimum dual spacing required by the tire manufacturer.

Demounting and Mounting Tires

CAUTION

DEMOUNTING, MOUNTING AND INFLATION OF TIRES SHOULD BE COMPLETED BY A PROPERLY TRAINED, EXPERIENCED AND EQUIPPED MECHANIC/TECHNICIAN. BODILY HARM OR DEATH CAN OCCUR IF CAUTION IS NOT EXERCISED DURING THIS PROCESS.

ADDITIONAL INFORMATION

Always use a safety device when inflating. Never stand over tire or in front of valve when inflating. Before final inflation, check the assembly carefully for apparent sign of weakness or irregularities.

TIRE MIXING

CAUTION

IMPROPER TIRE MIXING CAN BE DANGEROUS ON VEHICLES WITH FOUR OR MORE WHEEL POSITIONS. RADIAL AND NON-RADIAL TIRES SHOULD NOT BE MIXED IN A DUAL FITMENT.

Electrical System

LIGHTS AND WIRING

The lighting system for your trailer is a heavy duty, 12-volt, 30-amp system. The 7-way receptacle is located on the front of the trailer near the glad-hands. The jumper cable from the truck tractor plugs into the trailer's 7-way receptacle to complete the electrical circuit to the trailer. The receptacle is equipped with a hinge type cover to protect it from exposure to dirt and water. The same light switches that control the lights on the truck tractor control trailer lights.

Proper maintenance of the lighting system requires periodic cleaning of lamps, and reflectors to assure maximum visibility of the tractor and trailer. Use a damp cloth to wipe the lenses. A dry cloth will cause the dirt to act as an abrasive and scratch the lenses. A daily cleaning can be worth the time invested, plus, it's a good safety practice. Maintenance of the lighting and wiring system consists of an occasional inspection to see that all wiring connections are tight. Make sure the lighting units are securely mounted, and the wiring is not pinched or damaged. Inspect lights, couplings and sockets for their serviceability and replace as required.

NOTE

ALL FONTAINE TRAILERS MANUFACTURED AFTER MARCH 1, 1997 ARE WIRED TO PROVIDE CONSTANT POWER TO THE TRAILER'S ANTI-LOCK BRAKE SYSTEM (ABS) FROM THE CENTER PIN OF THE MAIN 7-WAY CONNECTOR AT THE FRONT OF THE TRAILER. IF YOU NEED HELP DETERMINING HOW YOUR PARTICULAR TRAILER IS WIRED, CONTACT FONTAINE TRAILER COMPANY AT 205-485-1300. Or email: techsupport@fontainetrailer.net

TURN SIGNAL and HAZARD FLASHER SYSTEM

The turn signal lever and hazard flasher are located in the truck tractor. To operate the turn signals, the ignition switch must be in the ON position. The hazard flasher system is operated independently of the ignition system in most cases. All turn signal lights can be made to flash simultaneously by pulling out the activating knob on the hazard flasher switch.

Two flasher units are used for the trailer. One unit is used in the turn signal circuit and the other for the hazard flasher system located in the truck tractor. The most common problems with the turn signals and hazard flasher system are defective flashers, burned-out bulbs, blown fuses, defective switches or faulty wiring.

REFLECTORS

Reflectors are located on the front, sides and rear sections of the trailer. They should be kept clean by wiping with a damp cloth. Replace any reflectors that are cracked or broken.

STOP, TAIL, TURN, MARKER & IDENTIFICATION LIGHTS

To remove lens and bulb with grommet mount installations, insert a screwdriver under the lens flange and pry lens out of the soft housing.

LICENSE LAMP

To remove license bulb from the license lamp, remove the mounting screws and remove license lamp cover. Follow the same instructions used for the clearance, marker and identification lights above. Re-install cover using the mounting screws.

CONSPICUITY/RETRO-REFLECTIVE TAPE

Proper maintenance of the conspicuity/retro reflective tape system is the responsibility of the owner/operator as outlined in DOT 49 CFR 393.11 (b). Conspicuity reflectivity requirements and vehicle coverage requirements are contained in CFR Part 571 under FMVSS 108 Regulations.



Care of Wood Decking for Platform Trailers

Platform trailers that set idle for periods of time are exposed to the elements where they may suffer weather damage. This damage results from excessive sunlight, temperature and/or moisture. The damage from sunlight and high temperatures may take the form of shrinkage to the top face of the decking causing larger than normal spacing to appear between boards. Often this will be accompanied by concave cupping of the decking, which is more pronounced in wider width pieces and cracking or splitting of the decking known as season checking. These cracks may cause other problems. The cracks fill with rainwater and absorption of water into the wood can lead to degradation as trapped water penetrates the interior portion of the boards.

Prevention of weather damage can be greatly minimized by applying a good water repellent wood preservative to all visible surfaces of the decking. The cost of labor to apply the treatment and the material is modest when compared to the potential degradation from the weather elements. It takes less than one hour of labor and approximately four gallons of repellent using a hand roller or preferably, a hand held pump up sprayer.

Various types of products used are Thompson's and Baer's Waterseal, linseed oil and Wood Guard* which contains a preservative agent that may produce better results. Any of these products will help increase the life of the decking. Incorporate a maintenance program for coating the decking will benefit the end user, especially if the trailer has been setting idle for any length of time.

Applying UV-inhibitors and water repellents twice annually (spring and fall) creates the best results. A liberal coating when trailer is new will begin the process of limiting the effects of the environment.

Remember, wood is a product of nature and will acclimate to its surrounding environment. Properly seasoned decking can change dimensions after installation given the right conditions and excessive swings in the environment (winter/summer) will take its toll on decking. Platforms setting dead lined or idle are subject to a different environment than those in operation even in the same locations.

*Wood Guard by ISK Biosciences, Memphis, TN (800-524-1093).



Brakes

To directly assist in keeping your trailer on the road and rolling, the following troubleshooting guide has been prepared for your convenience. You can avoid

serious delay and downtime in servicing your trailer if the cause of the trouble can be diagnosed and corrected quickly by you.

BRAKES WILL NOT RELEASE	
Probable Cause	Remedy
1. Low air Pressure	1. Check air line connections & verify sufficient air in tank
2. Brake shoes bound up at cams	2. Lubricate brake operating parts.
3. Brake out of adjustment.	3. Adjust brakes.
4. Damaged brake assembly.	4. See your nearest Fontaine Service Center
5. Source of air supply shut off at tractor	5. Push control valve IN

NO BRAKES OR INSUFFICIENT BRAKES	
Probable Cause	Remedy
1. Low brake line pressure	1. Check air pressure gauge on tractor - Inoperative
2. Brake lines between tractor and trailer not properly coupled	2. Properly couple brake lines
3. Reservoir drain cock open	3. Close drain cock.

SLOW BRAKE APPLICATION OR RELEASE	
Probable Cause	Remedy
1. Lack of lubrication	1. Lubricate brake operating parts
2. Excessive pushrod travel in spring brake air chamber	2. Adjust brakes
3. Restriction in hose or line	3. Replace broken hose or line
4. Defective brake valve	4. Replace brake valve

BRAKES GRABBING	
Probable Cause	Remedy
1. Foreign material on brake lining	1. Reline brakes
2. Brakes out of adjustment	2. Adjust brakes
3. Brake drum out-of-round	3. Replace brake drum
4. Damaged brake chamber or internal assembly	4. See your nearest Fontaine Service Center
5. Leaky or broken hose between relay valve and brake chamber	5. Replace or repair as required

BRAKES DRAGGING	
Probable Cause	Remedy
1. Out of adjustment	1. Adjust brakes
2. Binding cam, anchor pins or chamber rod end pin	2. Lubricate and free up
3. Damaged brake assembly or brake drum out-of-round	3. Replace. See your nearest Fontaine Service Center



Wheels, Tires and Alignment

PULLING HARD	
Probable Cause	Remedy
1. Broken or cracked spring	1. Replace complete spring
2. Uneven load distribution	2. Rearrange load for proper distribution
3. Weak spring	3. Replace complete spring
4. Axle out of alignment	4. Align axle
5. Tracking to one side or excess tire wear	5. Align axle

WHEELS, HUBS AND TIRES	
Probable Cause	Remedy
1. Tire wobble due to uneven rim clamping	1. Torque tighten all rim clamps
2. Burnt, worn or damaged wheel bearings	2. Replace bearings
3. Bent wheel or rim	3. Replace wheel or rim
4. Bent axle	4. Replace axle

SCUFFED TIRES	
Probable Cause	Remedy
1. Over and under inflation	1. Inflate to proper pressure
2. Excessive speed on turns	2. Reduce speed

TRACKING TO ONE SIDE	
Probable Cause	Remedy
1. Leaf spring broken	1. Replace complete spring
2. Bent axle	2. Replace axle
3. Axles out of alignment	3. Align axles

LOSS OF TIRE AIR PRESSURE	
Probable Cause	Remedy
1. Puncture in tire	1. Repair or replace tire
2. Faulty valve or valve core	2. Replace valve assembly or core

UNEVEN TIRE WEAR	
Probable Cause	Remedy
1. Over and under inflation	1. Inflate to proper pressure
2. Loose wheel stud nuts or clamps	2. Tighten wheel stud nuts or clamps
3. Loose or tight wheel bearing adjustment	3. Adjust bearings
4. Axle bent or out of alignment	4. Replace axle
5. Tires not properly matched	5. Match tires
6. Improper brake actuation	6. Correct brakes as required
7. Rapid stopping	7. Apply brakes slowly when approaching stop
8. High speed driving on turns	8. Reduce speed



Landing Gear

DIFFICULTY IN TURNING HANDCRANK	
Probable Cause	Remedy
1. Bent crank shaft	1. Straighten or replace shaft
2. Bent cross shaft	2. Replace shaft
3. Lack of lubricant or correct lubricant	3. Lubricate in accordance with lubrication chart
4. Gears or components damaged	4. Free up or replace
5. Jackscrew nut jammed	5. Replace inner leg assembly

Electrical System

WIRING, FUSES & CIRCUIT BREAKER	
Probable Cause	Remedy
1. Circuit breaker kicks off	1. Correct short. Splice or repair wiring
2. Wires burned	2. Replace wiring
3. Contact points dirty or corroded	3. Remove lamp unit and clean
4. Loss of ground at bulb	4. Repair as necessary

COMPLETE LOSS OF TRAILER LIGHTS	
Probable Cause	Remedy
1. Broken main harness	1. Repair or replace wire
2. Blown fuse or breaker	2. Replace fuse
3. Broken ground lead between tractor and trailer	3. Check, repair or replace jumper cable if equipped
4. Loose or corroded connection in ground lead between tractor and trailer	4. Repair or replace

DIM OR FLICKERING LIGHTS	
Probable Cause	Remedy
1. Battery on tractor not sufficiently charged	1. Change battery
2. Damaged wire in jumper cable	2. Repair or replace wire
3. Dirty or corroded contact blades	3. Clean contact blades
4. Loose connection	4. Repair as necessary
5. Poor ground at socket	5. Repair as necessary



Fontaine Trailer Parts

Always insist on Fontaine parts and service.
To find the Fontaine service center and dealer nearest you visit www.fontainepartsource.com
or email: parts@fontainetrailer.net

VELOCITY

FONTAINE
PARTSOURCE

EASY

We make it easy!
www.fontainepartsource.com



NHTSA Reporting

If you believe that your vehicle has a defect which could cause a crash or could cause injury or death, you should immediately inform the **National Highway Traffic Safety Administration (NHTSA)** in addition to notifying FONTAINE TRAILER COMPANY.

If NHTSA receives similar complaints, it may open an investigation, and if it finds that a safety defect exists in a group of vehicles, it may order a recall and remedy campaign. However, NHTSA cannot become involved in any individual problems between you, your dealer or FONTAINE TRAILER COMPANY.

To contact NHTSA you may either call the Auto Safety Hotline toll-free at 1-800-424-9393 (366-0123 in Washington DC area) or write:

NHTSA
U.S. DEPARTMENT OF TRANSPORTATION
400 7th Street SW, (NSA-11)
Washington, DC 20590

You can also obtain other information about motor vehicle safety from the NHTSA Hotline.

FONTAINE TRAILER COMPANY
P.O. Box 619
430 Letson Rd
Haleyville, AL 355656
Toll-Free: 1-800-821-6535
www.fontainetrailer.com



APPENDIX: Component Manufacturers

AXLES and SUSPENSION:

Hendrickson
Trailer Suspension Systems
2070 Industrial Place SE
Canton, OH 44707-2600
Phone: (800)-455-0043
www.hendrickson-intl.com

Hutchens Industries, Inc.
P.O. Box 1427
Springfield, Missouri 65801-1427
Phone: (800)-654-8824

ArvinMeritor
2135 West Maple Road
Troy, MI 48084 USA
Phone: (800)-535-5560
www.arvinmeritor.com

BRAKE SYSTEMS:

Meritor WABCO
Vehicle Control Systems
2135 West Maple Road
Troy, MI 48084 USA
Phone: (800)-535-5560
www.meritorwabco.com

Haldex Brake Products
10707 N.W. Airworld Drive
Kansas City, MO 64153-1215
Phone: (816) 891-2470
www.hbsna.com

Meritor (Auto Slacks)
Meritor Heavy Vehicle Systems
2135 West Maple Road
Troy, MI 48084 USA
Phone: (800)-535-5560
www.drivetrainplus.com

Sealco Commercial Vehicle Products
215 East Watkins Street,
Phoenix, Arizona 85004
Phone: (602) 253-1007
www.sealcocvp.com

MGM Brakes
8530 Cliff Cameron Drive
Charlotte, NC 29269-9786
Phone: (800) 527-1534
www.MGMBrakes.com

Knorr/Bendix
901 Cleveland Street
Elyria, Ohio 44035
Toll-Free: 1-800-AIR-BRAKE
http://www.bendix.com/

TSE Brakes
2310 Industrial Drive S.W.
Cullman, AL 35055
http://www.tsebrakes.com

TIRE INFLATION SYSTEMS:

Hendrickson
Trailer Suspension Systems
(See Above)

Meritor WABCO
(See Above)

LIGHTS / HARNESES:

Truck-Lite Company, Inc.
310 E Elmwood Ave.
Falconer, NY 14733
Phone: (800) 562-5012
www.truck-lite.com

Phillips Industries
12012 Burke Street
Santa Fe Springs, CA 90670
Phone: (800) 423-4512
www.phillipsind.com

Peterson Manufacturing Co.
4200 E. 135th Street
Grandview, MO 64030
Phone: (816) 765-2000
www.pmlights.com

Grote Industries, Inc.
2600 Lanier Drive
Madison, IN 47250
Phone: (812) 273-1296
www.grote.com

APPENDIX: Component Manufacturers

WHEELS

Hayes Lemmerz International, Inc.
Akron Operations
428 Seiberling Street
Akron, OH 44306-3282
Wheel & Rim Customer Service:
Phone: (800) 337-0457 or 0458
<http://ch.hayes-lemmerz.com>

Accuride Corporation
7140 Office Circle
P.O. Box 15600
Evansville, IN 47716-0600
Phone: (888) 770-7282
www accuridecorp.com

Alcoa Inc. Wheel Products
1600 Harvard Avenue
Cleveland, OH 44105
Phone: (800) 242-9898
www.alcoa.com

APPENDIX: Trailer Decals for Readability

THE FOLLOWING ARE ANCHOR POINTS (IF TRAILER IS SO EQUIPPED) AND HAVE THE WORKING LOAD LIMIT (WLL) AS NOTED:

- POCKET OR SPOOL WRAP
- PIPE SPOOLS - WLL = 5400 LBS / 24kN
- STEEL STAKE POCKETS - WLL = 5400 LBS / 24kN
- ALUM. STAKE POCKETS - WLL = 5400 LBS / 24 kN
- CHAIN TIE DOWNS - WLL = 5400 LBS / 24 kN
- WINCH TRACK - WLL = 5400 LBS / 24 kN

50507000

TO WRITE ON THIS LABEL USE AN INDELIBLE, PERMANENT INK MARKER, PEN OR PENCIL THAT WILL NOT FADE IN DIRECT SUNLIGHT

ANNUAL VEHICLE INSPECTION LABEL

COMPLETED: MONTH _____ YEAR _____

A RECORD OF THIS VEHICLE'S ANNUAL VEHICLE INSPECTION REPORT IS

MAINTAINED AT: MOTOR CARRIER OTHER ENTITY

COMPANY / NAME

STREET ADDRESS

CITY, STATE, ZIP CODE

TELEPHONE

MOTOR CARRIER IDENTIFICATION NUMBER

CERTIFICATION: THIS VEHICLE HAS PASSED AN INSPECTION IN ACCORDANCE WITH 49CFR 396.17 THROUGH 396.23.

VEHICLE IDENTIFICATION: IF THE VEHICLE IS NOT READILY, CLEARLY, AND PERMANENTLY MARKED, CHECK ONE AND COMPLETE.

- FLEET UNIT NUMBER
- LICENSE / REGISTRATION NUMBER
- VEHICLE IDENTIFICATION NUMBER
- OTHER _____

50507098-M

! CAUTION

"AIR RIDE SUSPENSION"

ALL AIR MUST BE DRAINED FROM SYSTEM BEFORE PARKING LOADED TRAILER ON LANDING GEAR. FOR THIS APPLICATION AN AIR DUMP VALVE MUST BE INSTALLED TO DRAIN THE AIR RIDE BAGS.

DO NOT MOVE LOADED TRAILER UNTIL AIR SYSTEM IS FULLY CHARGED AND ALL AIR BAGS ARE INFLATED.

08008



APPENDIX: Trailer Decals for Readability

NOTICE

PROPER TORQUE MUST BE MAINTAINED ON ALL BOLTS.
 TORQUE VALUES ARE FOR CLEAN DRY THREADS.
 RETORQUE AT 90 DAY INTERVALS AS FOLLOWS:

1/4" DIA., N.C., GR.5 HEX HEAD BOLTS	5 FT.-LB.
5/16" DIA., N.C., GR.5 HEX HEAD BOLTS	10 FT.-LB.
3/8" DIA., N.C., GR.5 HEX HEAD BOLTS	15 FT.-LB.
1/2" DIA., N.C., GR.5 HEX HEAD BOLTS	40 FT.-LB.
1/2" DIA., N.C., GR.8 HEX HEAD BOLTS	70 FT.-LB.
1/2" DIA., N.C., TORX FLATHEAD BOLTS	58 FT.-LB.
5/8" DIA., N.C., GR.8 HEX HEAD BOLTS	150 FT.-LB.
5/8" DIA., N.C., TORX FLAT HEAD BOLTS	110 FT.-LB.
3/4" DIA., N.C., GR.8 HEX HEAD BOLTS	220 FT.-LB.

NOTE: SUSP. BOLT TORQUE LABEL LOCATED AT REAR.
08037B

NOTICE

1. Proper coupling height should be maintained between tractor and trailer. **DO NOT** impact trailer upon coupling engagement.
2. **DO NOT** load forward section of trailer without proper coupling support.

50507-63



FONTAINE TRAILER

Trailer Tare Weight

XXXX LB



APPENDIX: Trailer Decals for Readability

FINAL INSPECTION COMPLETE
SERIAL# _____
DATE _____
INSPECTOR _____
FONTAINE TRAILER COMPANY

 <p>1 WHT 6 BRN 7 BLU 2 BLK 5 GRN 4 RED 3 YEL 12V.</p> <p>STANDARD</p>	<p>! CAUTION</p> <p>This trailer is equipped with antilock brakes. Continuous power (12V.) must be supplied on No. 7 pin of standard connector. A cab switch must supply power (12V.) to pin identified on auxiliary connector for accessories.</p> <p>50507086</p>	 <p>1 WHT 6 BRN 7 BLU 2 BLK 5 GRN 4 RED 3 YEL</p> <p>AUXILIARY</p>
--	--	--

 <p>FONTAINE TRAILER</p>	<p>This product is manufactured under the following United States Patents 7,571,953, 7,568,764 and other patents pending</p> <p>50507441</p>
--	--



APPENDIX: Trailer Decals for Readability

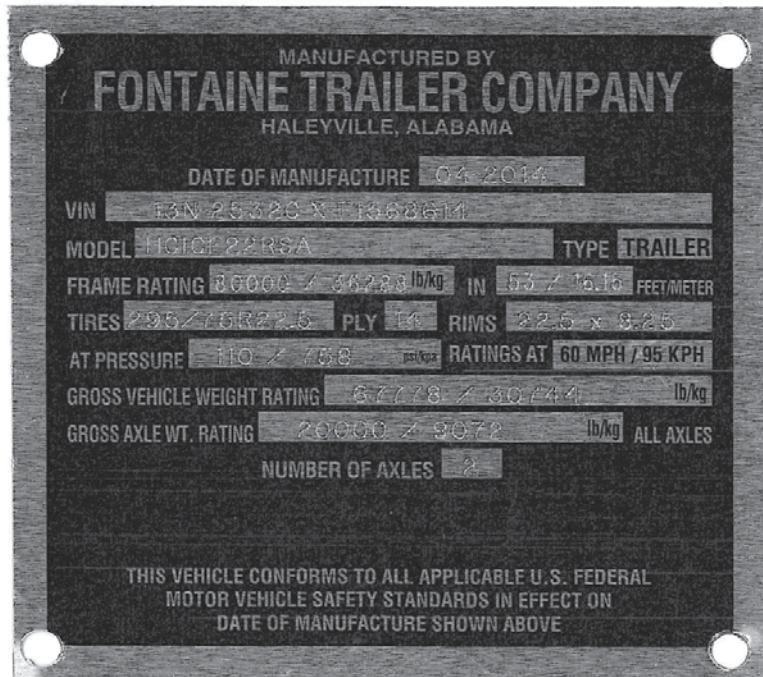

APPENDIX: Trailer Decals for Readability

NOTICE:

If the ABS indicator lamp comes on *and* stays on when you apply the brakes to a *moving* vehicle, the trailer ABS is not working properly. The ABS must be serviced as soon as possible upon completion of your trip to ensure full anti-lock braking capability.

TP-95172



Rev. 7/01

HENDRICKSON EXTENDED-LIFE 5-YEAR SYSTEM™ (HXL5™) WHEEL END

- * **DO NOT** remove the HXL5™ hubcap without first contacting Hendrickson Technical Services Department in the United States at 866-RIDEAIR (743-3247) or in Canada at 800-668-5360.
- HXL5™ is equipped with a PRECISION320™ nut system on a HP spindle or a PRECISION240™ nut system on a HN spindle.
- Do not add lubricant, hub is pre-filled with Chevron Delo SF grease.
- Quarterly rotate wheel end to ensure smooth, quiet rotation (T72007). If not, contact Hendrickson. *
- Monthly visually inspect hubcap and back of hub for evidence of lube leaks.

NOTE: Wheel-end repairs performed prior to contacting Hendrickson Technical Services voids the warranty. Refer to L583 for details.

Trailer Commercial Vehicle Systems
2070 Industrial Place SE
Canton, OH 44707-2641 USA
866-863-5468 (743-3247)
330.489.0045
Fax 800.696.4416



Hendrickson Canada
250 Chrysler Drive, Unit #3
Brampton, ON Canada L6S 6B6
905.789.1030
Fax 905.789.1033

T72006 07-12 EON 21213

©2012 Hendrickson USA, L.L.C. All Rights Reserved

Printed in United States of America

HENDRICKSON LONG-LIFE SYSTEM™ (HLS™) WHEEL END

This unit is equipped with the Hendrickson Long-life System™ (HLS™) wheel end, which is factory lubricated with a synthetic semi-fluid grease.

- Do not add lubricant, wheel end is factory lubricated
- Do not attempt to adjust bearings, they are factory pre-adjusted
- Hub removal voids warranty

DO NOT remove the HLS™ hubcap without first contacting Hendrickson technical service at 800-455-0043 in the United States or 800-668-5360 in Canada.

Trailer Suspension Systems
2070 Industrial Place SE
Canton, OH 44707-2600 USA
800.455.0043
330.489.0045
Fax 800.696.4416



Trailer Suspension Systems
250 Chrysler Drive, Unit #3
Brampton, ON L6S 6B6 Canada
905.789.1030
Fax 905.789.1033

L831 07-03 Printed in the United States of America.

www.hendrickson-hifi.com

Copyright ©2003. All Rights Reserved.



VELOCITY

APPENDIX: Trailer Decals for Readability

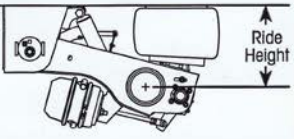
<p>INTRAAX® SUSPENSION INSPECTIONS</p> <p>Inspect the following items during regular vehicle maintenance:</p> <ul style="list-style-type: none"> • Vehicle frame, suspension beams, brackets and other structural components for cracks or other damage • All fasteners for proper torque or damage • All welds for cracks or other damage • Air springs for chafing, rubbing or damage • Shock absorbers for leaks or damage • Suspension ride height 	<p>INTRAAX TORQUE SPECIFICATIONS</p> <table style="width: 100%; border: none;"> <tr> <td>QUIK-ALIGN® Pivot Bolt</td> <td style="text-align: right;">505-595 ft. lbs. (685-807 N•m)</td> </tr> <tr> <td>Shock Bolt (Upper and Lower)</td> <td style="text-align: right;">210-235 ft. lbs. (285-319 N•m)</td> </tr> </table> <p>Do not reuse bolts. For more torque specification, refer to Hendrickson publication B31. For pivot connection fastener information, refer to Hendrickson publication B92. All Hendrickson publications can be found online at www.hendrickson-intl.com.</p> <p style="text-align: center;">CAUTION</p> <p>USE OF LUBRICANT OR ANTI-SEIZE COMPOUND can cause over tightened fasteners, unpredictable pivot connection clamp loads and unreliable axle alignments. Do not apply lubricant or anti-seize compound to pivot connection hardware.</p> <p style="text-align: center;">HENDRICKSON</p> <p style="text-align: center;">www.hendrickson-intl.com</p> <table style="width: 100%; border: none; font-size: small;"> <tr> <td style="width: 50%;"> Trailer Commercial Vehicle Systems 2070 Industrial Place SE Canton, OH 44707-2641 USA 866.RIDEAIR (743.3247) 330.469.0045 FAX 800.696.4416 </td> <td style="width: 50%;"> Hendrickson Canada 250 Chrysler Drive, Unit #3 Brampton, OH Canada L6S 6B6 905.769.1030 FAX 905.769.1033 </td> </tr> </table>	QUIK-ALIGN® Pivot Bolt	505-595 ft. lbs. (685-807 N•m)	Shock Bolt (Upper and Lower)	210-235 ft. lbs. (285-319 N•m)	Trailer Commercial Vehicle Systems 2070 Industrial Place SE Canton, OH 44707-2641 USA 866.RIDEAIR (743.3247) 330.469.0045 FAX 800.696.4416	Hendrickson Canada 250 Chrysler Drive, Unit #3 Brampton, OH Canada L6S 6B6 905.769.1030 FAX 905.769.1033
QUIK-ALIGN® Pivot Bolt	505-595 ft. lbs. (685-807 N•m)						
Shock Bolt (Upper and Lower)	210-235 ft. lbs. (285-319 N•m)						
Trailer Commercial Vehicle Systems 2070 Industrial Place SE Canton, OH 44707-2641 USA 866.RIDEAIR (743.3247) 330.469.0045 FAX 800.696.4416	Hendrickson Canada 250 Chrysler Drive, Unit #3 Brampton, OH Canada L6S 6B6 905.769.1030 FAX 905.769.1033						
<p>INTRAAX SUSPENSION SAFETY</p> <p style="text-align: center;">CAUTION</p> <p>IMPROPER AIR SPRING PRESSURE CAN CAUSE DAMAGE TO THE VEHICLE OR SUSPENSION OR SEVERE PERSONAL INJURY. DO NOT OPERATE THE VEHICLE WITHOUT AIR PRESSURE IN AIR SPRINGS. Lower trailer onto internal air spring bumpers if it is supported by the landing gear legs and parked with a payload for any length of time. Lower the trailer onto internal air spring bumpers for safe loading and unloading.</p>							
L975 Rev A 04-12 ECN 21107	©2012 Hendrickson USA, L.L.C. (U.S. Rights) Hendrickson Intl Corp (Rights Outside U.S.) All Rights Reserved	Printed in United States of America					

<p><u>OPERATION</u></p>  <p>CRANK</p> <p>RETRACT EXTEND</p> <p>HIGH GEAR - SHIFT IN LOW GEAR - SHIFT OUT</p>	<p>JUST</p> <p>MAINTENANCE FREE</p> <p>FOR 5 YEARS</p> <p>FROM IN-SERVICE DATE</p> <p style="font-size: x-small;">www.jostinternational.com</p>	<p><u>MAINTENANCE</u></p> <p>AFTER 5 YEARS</p> <p>LUBRICATE ALL</p> <p>GREASE FITTINGS</p> <p>EVERY 90-DAYS</p> <p>W/ 4 oz. EP GREASE</p>
---	--	--

This Trailer Is Equipped With:

MERITOR™

Meritor Tire Inflation Systems by P.S.I.

When the tire light is on for more than 10 minutes, report it to your dispatcher or maintenance supervisor. The light means your tire is being inflated to the proper cold temperature pressure and may have a serious leak that will need repair.

(888) 725-9355 / (800) 535-5560

*P.S.I.'s ATIS is covered by one or more of the following U.S. patents:
5,769,979, 6,131,631, 6,892,778, 6,698,482, 7,416,005.*



APPENDIX: Trailer Decals for Readability

For replacement parts or technical service see the experts at your local Fontaine PartSource Dealer.



To find the closest dealer visit our website or call today!
www.fontainepartsource.com
 866-382-7278

! WARNING

WHEN SECURING CARGO TO THIS TRAILER PROPER JUDGEMENT MUST BE USED WITH CHAIN-TIE-DOWNS, WINCHES, CHAIN WRAPPED AROUND SPOOL AND HOOKED PROPERLY TO POCKET, CHAIN AROUND SINGLE AND DOUBLE SPOOLS. WINCH STRAP TO J-HOOK BAR. MAXIMUM LOAD NOT TO EXCEED 5000 LBS. PER CARGO SECUREMENT POINT.

080748

TORQUE SPECIFICATIONS (FOR PILOT MOUNTED DISC WHEELS)

! DANGER

Read and Understand the installation, service and safety instruction manual before installing or servicing the hub. Failure to do so may result in personal injury or death, and may result in a compromise of your vehicle's safety through loss or failure of a wheel or compromise of the braking system.

Use a torque wrench to assure proper torque, failure to do so will compromise your products service, life and safety. Under torque and over torque can cause thread and/or nut damage, and may result in the loss of a wheel.

Recheck torque after the first 50 to 100 miles of service. Parts may seat naturally, causing the torque to drop. Proper torque is essential for service, life and safety of this product.

HUBS
 (FOR PILOT MOUNTED DISC WHEELS)

8 AND 10 STUD HUBS
 Applies to M22 x 1.5 studs/two piece flange nut.
 All threads are right hand metric.
 First tighten Flange Nut to 50 ft. lb. using sequence shown.



Check Disc-Wheel for proper positioning on pads and proper seating against flange.

Then Tighten Flange Nuts to recommended torque using sequence shown.

RECOMMENDED TORQUE 450- 500 FT. LBS.

! CAUTION

WINCH RESTRICTION AREA.
 REMOVE ALL WINCHES FROM THIS AREA BEFORE SLIDING SUSPENSION TO THE REAR.

50507124

NOTICE

This trailer is equipped with automatic slack adjusters. Consult maintenance manual before adjusting.

50507-65



VELOCITY

APPENDIX: Trailer Decals for Readability

AIR SLIDE AXLE REPOSITIONING PROCEDURE

1. Position the tractor with empty trailer on level ground, and clear all personnel away from tractor/trailer.
2. Apply the tractor parking brakes inside the cab.
3. Exit the cab and proceed to the slide axle.
 - A. Set the "Brake Lock/Air Spring Inflate" valve to the "Raised" position (If trailer is equipped with air springs). This inflates the air springs to raise the trailer body and also locks the slide axle brakes. This also isolates the slide axle from the rest of the braking system so that the slide axle brakes are not released in STEP 4A below.
 - B. Pull QUICK-DRAW™ valve out to retract the slide pins. Verify that the pins are fully retracted from the mainbeam on both sides of the trailer.
 - C. Verify clearance. Make sure that the trailer structure (siderail, winches, etc.) is raised sufficiently to clear the tires as the trailer is repositioned on the axle.
4. Return to the cab.
 - A. Release the tractor parking brakes. This releases all brakes on the tractor/trailer except for the slide axle brakes which were isolated from the rest of the braking system in STEP 3A above.
 - B. Slowly move the tractor forward or backward to the proper position. The slide axle remains stationary, allowing the trailer to be repositioned on the axle.
 - C. Apply the tractor parking brakes to immobilize the vehicle.
5. Exit the cab and proceed to the slide axle.
 - A. Visually inspect to make sure that the slide locking pins are aligned with the positioning holes in the trailer mainbeams. If they are not aligned, move the tractor slightly to make the necessary adjustment.
 - B. Push the QUICK-DRAW™ valve in. This will push the slide pins through the positioning holes in the mainbeams.
 - C. Make sure that the slide locking pins on both sides of the trailer are fully engaged in the mainbeam positioning holes. If not engaged, gently rock the tractor/trailer back and forth until they are fully engaged.
 - D. Set the "Brake Lock/Air Spring Inflate" valve to the "Normal" position. This deflates the air springs to the normal ride height and reintegrates the slide axle brakes with the rest of the tractor/trailer brake system.
6. Return to the cab.
 - A. Release vehicle parking brakes. The slide axle is now integrated with the brake system allowing normal tractor/trailer operation.
 - B. Move the tractor/trailer forward and backward to confirm that the slide axle now moves with the trailer.
 - C. Apply vehicle service brakes to confirm that the slide axle stops with tractor/trailer.

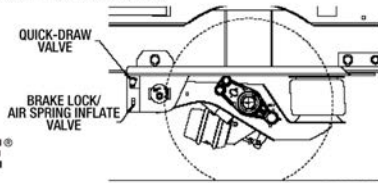

50507129 10/2015

WARNING!

Safety Alert!
Avoid pinch points!
Failure to heed this warning could cause serious injury or death.

TIREMAAX® TIRE INFLATION SYSTEM

This unit is equipped with the TIREMAAX® tire inflation system.

If the lamp remains on continuously for more than 10 minutes, one or more tires may be low or the system requires service.

In the event of a substantial system leak, set the trailer park brakes, then close controller supply valve.

For complete service details, refer to Hendrickson publication T51002, TIREMAAX Installation, Service and Troubleshooting Procedures, or call the Hendrickson Technical Services Department in the United States at 866-RIDEAIR (743-3247) or in Canada at 800-668-5360.

Trailer Commercial Vehicle Systems
2070 Industrial Plaza SE
Canton, OH 44707-2641 USA
866.RIDEAIR (743.3247)
330.489.0045
FAX 800.698.4416



Trailer Commercial Vehicle Systems
250 Chrysler Drive, Unit #3
Brompton, OH Canada L6S 6B6
905.789.1030
FAX 905.789.1033

T50014 08-11 ECN 20041

©2011 Hendrickson USA, L.L.C. (U.S. Rights) Hendrickson Intl Corp (Rights Outside U.S.) All Rights Reserved

Printed in the United States of America



Index

A

ABS NOTICE - Connector Wiring Change 14
 Accessing The Trailer Deck..... 19
 Anchor Points..... 20
 Anti-Lock Braking System 14
 Anti-Lock Braking System: Lamp Codes 15
 Axle Alignment..... 9

B

Basic Maintenance Schedule..... 33
 Basic Trailer Maintenance 34
 Brake Drum 40
 Brakes..... 45
 Bulkhead Securement 25, 26

C

Care of Wood Decking 44
 Chain 22
 Checking Trailer Ride Height..... 11
 Conspicuity 43
 Contents 2
 Coupling..... 16
 Coupling and Uncoupling 16

D

Decal Locations..... 5
 Decals if trailer has extra options..... 7
 Front Decals..... 5
 Side Decals..... 6
 Demounting and Mounting Tires..... 42

E

Electrical System 43, 47

F

Fifth Wheel 16
 Fontaine PartSource 48
 Fontaine Trailer Parts 48

H

Hazard Flasher System..... 43
 Hub/Wheel Installation and Maintenance 37

K

Kingpin 11

L

Landing Gear..... 8, 47
 Leaf Type Springs Care And Maintenance 35
 License Lamp..... 43
 Lights 43
 Lights and Wiring..... 43
 Load Securement: Anchor Points 20
 Load Securement: Chain Securement ... 22, 23, 24
 Load Securement: Winch and Strap 21
 Lubrication Notes 34

M

Maintenance
 Daily Intervals and Pre-Trip 33
 Monthly Intervals 33
 Six Month Intervals..... 33
 Maintenance Record 62



Index

N

NHTSA Reporting..... 49

O

Operating Instructions 3

Operating Limits And Restrictions..... 4

R

Reflective Tape 43

Reflectors 43

Reporting Safety Defects..... 49

Ride Height Measurement 11

S

Self Adjusting Slack Adjuster 39

Slack Adjuster 39

Sliding Suspension Operation 27

Sliding Suspension Positioning 27

Strap 21

Suspension System: Axle Alignment 9

 Single Axle Trailers 9

 Tandem Axle Trailers 10

Suspension System: Height Control..... 13

Suspension System: Ride Height Adjustment 11

T

Tire Maintenance 40

Trailer Preventive Maintenance program (TPM)..... 3

Trailer Ride Height 12

Troubleshooting

 Brakes 45

 Electrical System..... 47

 Landing Gear 47

 Wheels, Tires and Alignment 46

U

Uncoupling 18

W

Wheel and Rim Care..... 35

Wheel Bearings 36

Wheel Installation and Maintenance 37

Wheels, Tires and Alignment..... 46

Winch 21

Wood Decking..... 44



Fontaine Commercial Platform
430 Letson Road
Haleyville, Alabama 35565
800-821-6535
www.fontainetrailer.com

